



MPM-S106(-C)

100W Medical AC / DC

SPECIFICATION

For

SWITCHING POWER SUPPLY

M/N: MPM-S106(-C)

MPM-S106(-C)

100W Medical AC / DC

Revision History

Version	Revise Date	Change Items
Rev. 01	Aug. 13. 2012	Established.
Rev. 02	Aug. 31. 2012	Revised.
Rev. 03	Oct. 11. 2012	Added new model: MPM-S106 which is +48V output.
Rev. 04	Dec. 6. 2012	1.Derating curve. 2.Dip Voltage dips 30%, 25 cycles from A to A/B.
Rev. 05	Sep. 25. 2013	1.Add mechanical drawing. 2.Added max. output current. 3.Efficiency up to 91%.
Rev. 06	Oct. 16. 2013	Change derating curve.
Rev. 07	Nov. 7. 2013	Change derating curve for MPM-S106.
Rev. 08	Feb. 18. 2014	Added optional cover kit drawing and its derating curve.
Rev. 09	Jul. 1. 2015	Added TUV logo.
Rev. 10	Jul. 22. 2015	Changed Molex Housing part no.
Rev. 11	Aug. 27. 2015	Changed Safety Approvals for UL approved.
Rev. 12	Sep. 10. 2015	Changed IEC 60601-1: 2005 3rd Edition for UL approved.
Rev. 13	Nov. 25. 2015	1.Added "or equivalent" after "Molex" and "JST". 2.Changed Molex Proposed Terminals from 5176 to 5167. 3.Added vibration test.
Rev. 14	May. 23. 2016	Added Performance Curves of MPM-S105-C convection cooled.
Rev. 15	Jan. 23. 2017	1.Added "Designed to meet IEC 60601-1-2 4th ed. EMC". 2.Changed IEC 61000-4-11 Voltage interruptions >95%, 250 cycles to C.
Rev. 16	Dec 21. 2017	1.Added performance curve with case. 2.Changed Form.
Rev. 17	Mar. 9. 2018	1.Added Designed to meet IEC 60601-1-2 4th ed. EMC. 2.Changed EMC and Safety Approvals.
Rev. 18	Jul. 3. 2018	Changed mechanical diagram.
Rev. 19	Nov. 6. 2018	1.Changed EMC: Immunity ESD to ±15KV air discharge, ±8KV contact discharge. 2.Changed EMC: Immunity Power Magnetic to 30A/m.



MPM-S106(-C)

100W Medical AC / DC



FEATURES

- ✓ 100W with convection-cooled single output power supply.
- ✓ High efficiency up to 91%.
- ✓ No-load power consumption < 0.5W.
- ✓ Class II design, additional class I functional ground connected.
- ✓ Compact size 2 x 4 inch and low profile.
- ✓ Medical standard EN / UL 60601-1 3rd Edition approved.
- ✓ Designed to meet IEC 60601-1-2 4th ed. EMC.
- ✓ Meets EMI CISPR/FCC class B.
- ✓ Optional cover kit.
- ✓ Designed to meet IEC 60601-1-2 4th ed. EMC.

Models & Ratings

Model Number	Wattage (Rated / Max)	Output Voltage	Min. Current	Rated Current	Max. Current
MPM-S106	100 W / 115 W	+48 V	0 A	2.1 A	2.4 A

Total Output Power: Max. 100W convection cooled, above 101~115W with 7 CFM forced air-cooling at 50°C environment temperature. Please see detail performance curves as below.

Note:

1. Model no. coding:

MPM-S10 X - Y - Z

① ② ③



①

X =	Output (V)
6	+48

②

③

Z =	Optional cover
Blank	Open frame
C	With optional cover kit

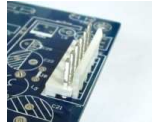
Y=	Input Connector Type	Output Connector Type
blank	Molex Type Connector or equivalent	Molex Type Connector or equivalent
		
J	JST Type Connector or equivalent	JST Type Connector or equivalent
		
Please refer to paragraph 8 for detail.		

Summary

Characteristic	Minimum	Typical	Maximum	Units	Notes & Conditions
Input Range	85	115 / 230	264	VAC	Universal input range.
Input Frequency	47	50 / 60	63	Hz	AC input.
Efficiency		90		%	At input 230VAC, rated load, 0.5 hr. warm up.
Operation Temperature	-20		+70	°C	Derate linearly above 50 °C, please refer to the following performance curves.
Weight		151.8		g	
Dimensions	101.6 (L) x 50.8 (W) x 33.0 (H) mm, Tolerance +/- 0.4mm.				
EMC	EN 55011 / CISPR 11 & FCC Part 18, EN 60601-1-2, EN 61000-3-2, EN 61000-3-3, IEC 61000-4-2, IEC 61000-4-3, IEC 61000-4-4, IEC 61000-4-5, IEC 61000-4-6, IEC 61000-4-8, IEC 61000-4-11				
Safety Approvals	IEC 60601-1: 2005, 3 rd Edition, EN 60601-1: 2006, 3 rd Edition, ANSI/AAMI ES60601-1:2005, 3 rd ed. CAN/CSA-C22.2 No. 60601-1 (2008)				

MPM-S106(-C)

100W Medical AC / DC

Input

Characteristic	Minimum	Typical	Maximum	Units	Notes & Conditions
Input Voltage	85	115 / 230	264	VAC	Universal input range.
Label Voltage	100		240	VAC	
Input Frequency	47	50 / 60	63	Hz	AC input.
Input Current			2 / 1.2	A	Nominal AC Input Voltage (115VAC/230VAC), rated load.
Inrush Current			30 / 60	A	Nominal AC Input Voltage (115VAC/230VAC), one cycle at 25°C cold start.
No-load power consumption			<0.5	W	Nominal AC Input Voltage (115VAC/230VAC).
Input Protection	Dual non-user serviceable internally located AC input line fuse. Fuse : 3.15A / 250VAC * 2pcs				

Output

Characteristic	Minimum	Typical	Maximum	Units	Notes & Conditions
Output Voltage		48		VDC	
Initial Set Accuracy	47.5		48.5	V	Initial setting accuracy is adjusted at input 115VAC and output at 60% rated load.
Minimum Load		0		A	
Start Up Delay		0.7		Sec	Nominal AC Input Voltage (115VAC/230VAC), rated load at 25°C. Time required for initial output voltage stabilization.
Hold Up Time	12 / 20			mS	Nominal AC Input Voltage (115VAC/230VAC), rated load.
Line Regulation		±1.0		%	Less than ±1% at rated load with ±10% changing in input voltage.
Load Regulation		±1.0		%	Measured from 60% to 100% rated load and from 60% to 20% rated load (60% ±40% rated load).
Ripple & Noise		480		mV	Measured at rated load by a 20MHz bandwidth limited oscilloscope and each output is connected with a 10µF Electrolytic Capacitor and a 0.1µF Ceramic Capacitor.
Overvoltage Protection	For some reason the power supply fails to control itself, the build-in over voltage protection circuit will auto recovery the outputs to prevent damaging external circuits.				
Short Circuit Protection	Fully protected against output overload and short circuit. Automatic recovery upon of overload condition.				

MPM-S106(-C)

100W Medical AC / DC

General

Characteristic	Minimum	Typical	Maximum	Units	Notes & Conditions
Efficiency		90		%	At input 230VAC, rated load, 0.5 hr. warm up.
Isolation	IP to OP	4000		VAC	2 x MOPP
	IP to Ground	1500		VAC	2 x MOPP (Screw head to primary)
Switching Frequency		<65		KHZ	

Environmental

Characteristic	Minimum	Typical	Maximum	Units	Notes & Conditions
Low temperature start up	-40			°C	Some specification parameters maybe exceeded until after 20 minutes warm up period. <small>(Note 1)</small>
Operating Temperature	-20		+70	°C	Derate linearly above 50°C, please refer to the following performance curves.
Storage Temperature	-40		+85	°C	
Relative Humidity	5		95	%RH	Non-condensing.
Cooling	7			CFM	Forced-cooled > 115W
Operating / Non-Operating Altitude		3000 / 4000		m	
Vibration	0.26		6.09	G	Frequency Type: Sweep Frequency Frequency Range: 10~55 Hz Displacement: 1.0mm Sweep Rate: 60 minute / cycle Number of cycle: 1 cycle / axis Direction: X ,Y and Z axis

Note:
1. To start up unit, the output power should be derated to 20% rated load @ $V_{in} < 115VAC$, or derated to 40% rated load @ $V_{in} < 230VAC$, and don't need derated @ $V_{in} \geq 230VAC$.

Derating curve

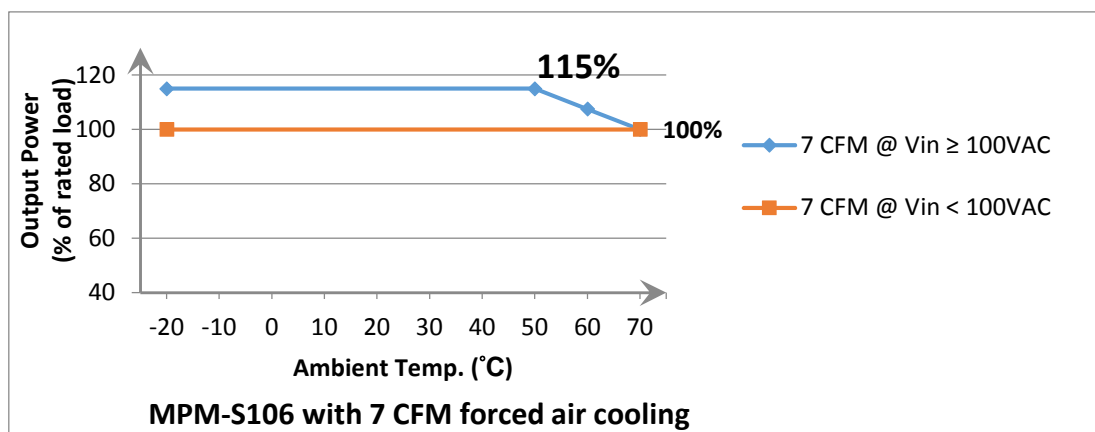



MPM-S106(-C)

100W Medical AC / DC

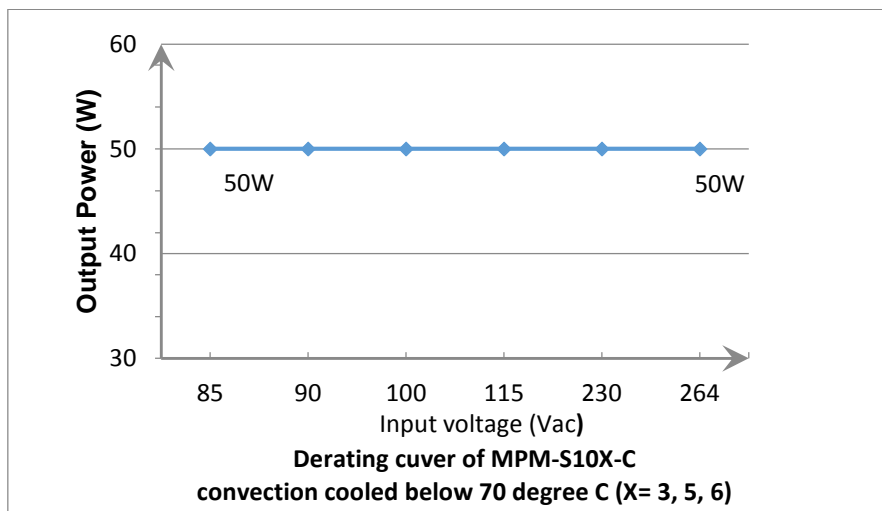
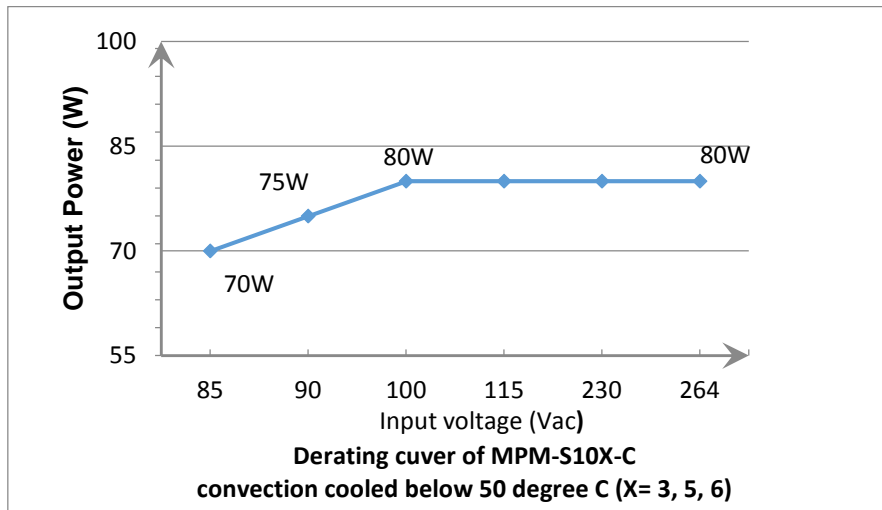
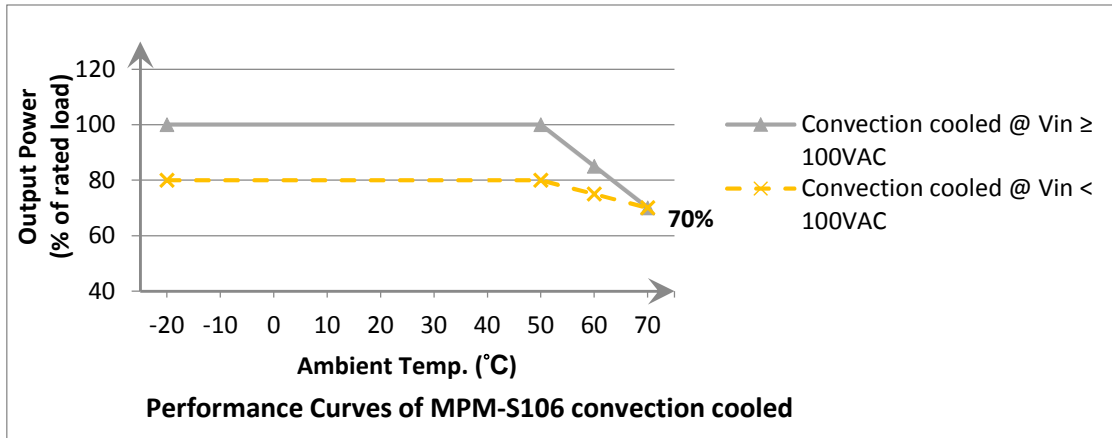



MPM-S106(-C)

100W Medical AC / DC

EMC: Emissions

Phenomenon	Standard	Class	Notes & Conditions
Conducted	EN 55011 / CISPR 11 & FCC Part 18, EN 60601-1-2	B	
Radiated	EN 55011 / CISPR 11 & FCC Part 18, EN 60601-1-2	B	
Harmonic Current	EN 61000-3-2	A	
Voltage Flicker	EN 61000-3-3		

- Note:
- As a build-in type power supply, the power supply needs to be installed in a suitable enclosure to pass the EMI/EMC tests. The final assembly has to comply with the valid EMI/EMC and safety.
 - The mounting holes should be connected to each other to conforming the EMI limit.
 - Apply to output equal or below 100W, for higher output power, please re-confirm with us.

EMC: Immunity

Phenomenon	Standard	Criteria	Notes & Conditions
ESD	IEC 61000-4-2	A	±15KV air discharge, ±8KV contact discharge
Radiated	IEC 61000-4-3	A	10V/m, 80 - 2700MHz
EFT	IEC 61000-4-4	A	±2KV Line & PE, 100KHz
Surges	IEC 61000-4-5	A	L-N:±1KV, L/N-PE:±2KV
Conducted	IEC 61000-4-6	A	10Vrms
Power Magnetic	IEC 61000-4-8	A	30A/m
Dips and Interruptions	IEC 61000-4-11	A A / B A / B C	DIP: >95%, 0.5 cycle DIP: 30%, 25 cycles ^(Note 2) DIP: 60%, 5 cycles ^(Note 2) INT: >95%, 250 cycles

- Note:
- Above specification is applied with output equal or below 100W. For higher output power, please re-confirm with us.
 - The test result of input 240Vac / 100Vac is criteria A / B.

Safety Approvals

Safety Agency	Safety Standard	Notes & Conditions
TUV	EN 60601-1: 2006, 3 rd Edition	Designed to meet.
CB	IEC 60601-1: 2005, 3 rd Edition	Approved.
UL/cUL	ANSI/AAMI ES60601-1:2005, 3 rd ed. CAN/CSA-C22.2 No. 60601-1 (2008)	Approved.



MPM-S106(-C)

100W Medical AC / DC

Mechanical Details

SIZE : 101.6(L) x 50.8(W) x 33.0(H)mm, Tolerance +/-0.4mm.

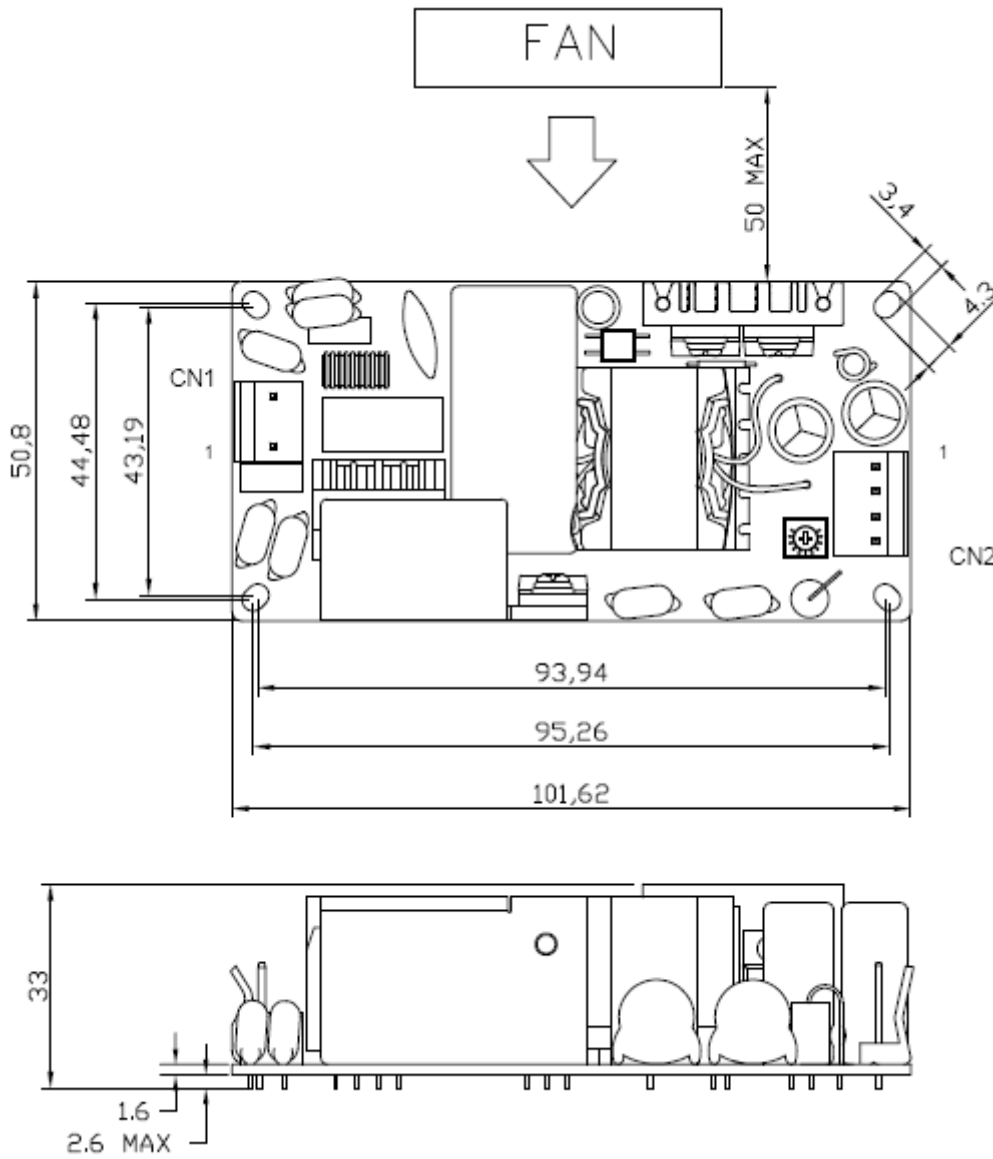



MPM-S106(-C)

100W Medical AC / DC

MPM-S106-C

108.7 (L) x 58.0 (W) x 38.4 (H) MM, TOLERANCE +/- 0.4MM.

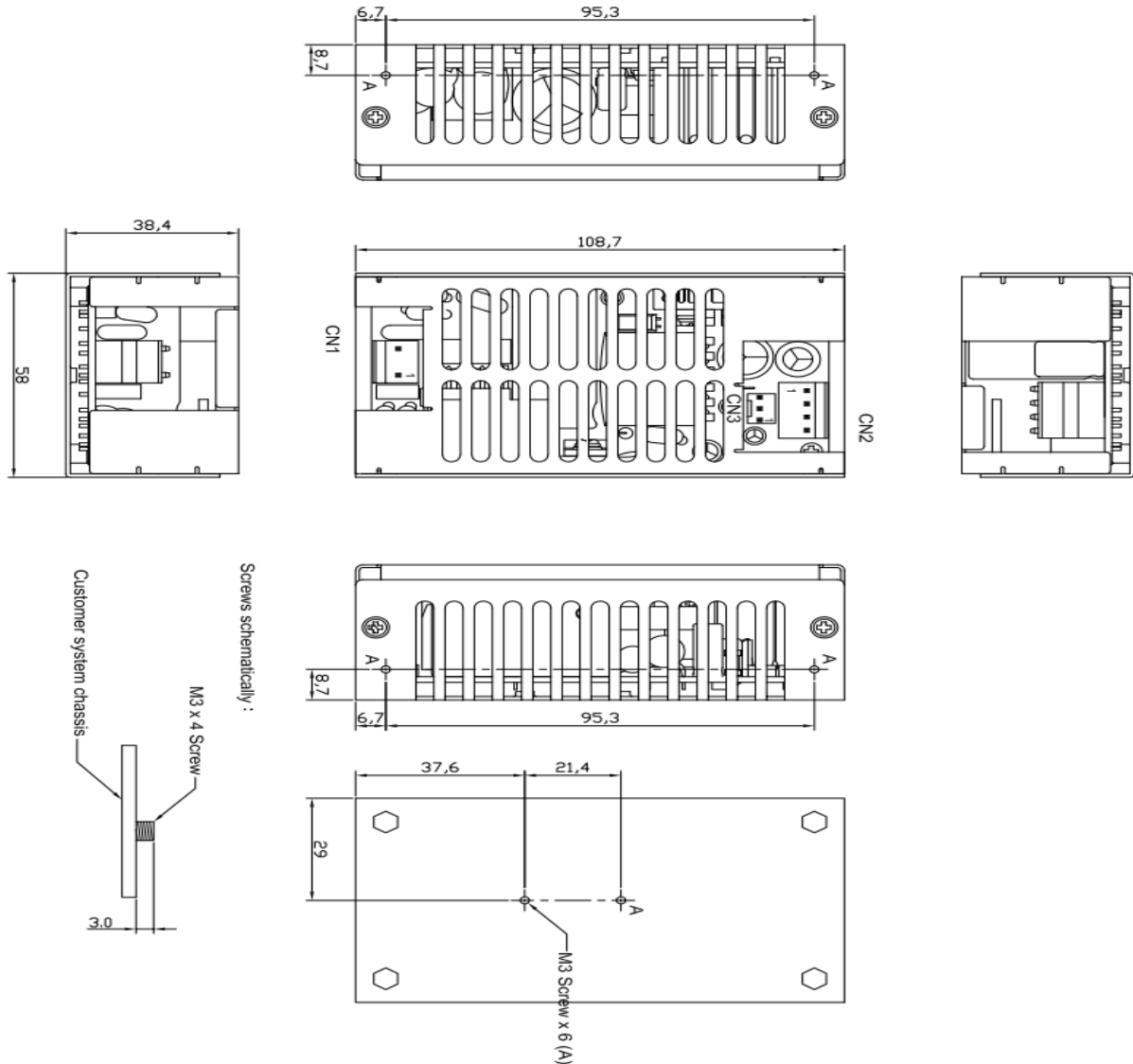

Parameter	Conditions/Description				
Dimension	101.6 (L) x 50.8 (W) x 33.0 (H) mm, Tolerance +/- 0.4mm.				
Connector & Pin Assignment	Location	Pin	Assignment	Proposed Housing	Proposed Terminals
	CN1 (Input)	1	AC in (L)	AC in (N)	MOLEX: 09-50-1031 (5195-03) or 09-52-4034 (5239-03) or equivalent;
2		AC in (N)	JST: VHR-3N (Note 1) or equivalent		JST: SVH-21T-P1.1 or equivalent
CN2 (Output)	1	0 V	0 V	MOLEX: 09-50-1041 (5195-04) or 09-52-4044 (5239-04) or equivalent;	MOLEX: 5194 or 5225 2478, 2578,5167 or 5168 or equivalent;
	2	0 V		JST: VHR-4N (Note 1) or equivalent	JST: SVH-21T-P1.1 or equivalent
	3	+ V			
	4	+ V			

Note: 1) Exist with model no. suffixed -J, please see the Model no. coding.

MPM-S106(-C)

100W Medical AC / DC

Thermal Considerations

In order to ensure safe operation of the PSU in the end-use equipment, the temperature of the components listed in the table below must not be exceeded.

Temperature should be monitored using J type thermocouples placed on the hottest part of the component (out of any direct air flow). See Mechanical Details for component locations.

Temperature Measurements at max. amb.	
Component	Max Temperature
T1	110°C
Q1	120°C
D6	120°C
C5	105°C
C9	105°C