

# Constant Voltage LED Power Supply

SLT30-12VFG-EU

SLT30-24VFG-EU



## Product description:

This type of power supply is an exclusively designed stabilized power supply for LED lamp. With constant voltage (CV) technology, it is suitable for constant voltage lamps (12/24VDC) connected in parallels. As an advantage of constant voltage (CV) technology, a switch can be installed between secondary side and lamps.

The built-in protection circuit will shut down the power supply in case of such faults as: open circuit, short circuit, over load or over temperature. The power supply will restart automatically after fault correction.

## Standards:

EN61347-1  
EN61347-2-13  
EN61547  
EN55015  
EN61000-3-2  
EN61000-3-3  
EN62384  
EN62493

## Characteristics:

- Independent power supply for constant voltage LED lamp
- Class II protection against electric shock from direct and indirect contact
- Super thin
- SELV output
- Open circuit, short circuit, over load and over temperature protection
- No load power consumption  $\leq 0.5W$
- Efficiency:  $\geq 85\%$  (AC230V, full load)

## Specifications :

Model	SLT30-12VFG-EU	SLT30-24VFG-EU	
Output	turn on time(S)	≤0.5	≤0.5
	output power(W)	30	30
	output votage(V)	12	24
	output voltage tolerance <sup>1</sup>	+/-3%	+/-3%
	ripple voltage(mV)	360(Vp-p)	480(Vp-p)
	working current range(A)	0-2.5	0-1.25
	dimming interface	No	
	dimming range	n/a	
Input	rated supply voltage(Vac)	220-240	220-240
	voltage range(Vac)	198-264	198-264
	line frequency(Hz)	50/60	50/60
	input current(mA)	170	170
	efficiency <sup>2</sup>	85%	85%
	average efficiency <sup>3</sup>	84.5%	82.5%
	no load power consumption(W)	≤0.5	≤0.5
	power factor <sup>2</sup>	0.95 @full load	0.95 @full load
	inrush current(lpk)	15A/35us	15A/35us
Protection	over voltage protection	YES	YES
	short circuit protection	YES	YES
	over temperature protection	YES	YES
	automatic restart	YES	YES
	over load protection	YES	YES
	surge capacity	L-N : 1KV	L-N : 1KV
Ambient and Life	Ta(°C)	-20...50	-20...50
	Tc max.(°C)	90	90
	Storage Temperature(°C)	-30...80	
	ambient humidity range	5%...85%, Not condensing	
	nominal life-time(hrs)	30000@Tc=85 C	
Other	weight(g)	125	120
	dimensions (LxWxH)(mm)	171x32x16.5	
	casing material	Plastic	
	housing colour	428C+Blue end cap	
	type of protection	IP20	
	protection class	Class2	
Note	<p>1. Tolerance:includes set up tolerance, line regulation and load regulation.  2. Tested at full load,230Vac.Refer to"Power Factor" and "EFFICIENT"curve graphs.  3. Calculate the model's average efficiency for each test voltage by testing at 100%, 75%, 50%, and 25% of rated current and then computing the simple arithmetic erage of these four values.  4. All parameters NOT specially mentioned are measured at nominal voltage input, rated load and 25 of ambient temperature.  5. The power supply is considered as a component that will be operated in combination with final equipment. Since EMC performance will be affected by the complete installation, the final equipment manufacturers must re-qualify EMC Directive on the complete installation again.</p>		

Dimensions(mm):

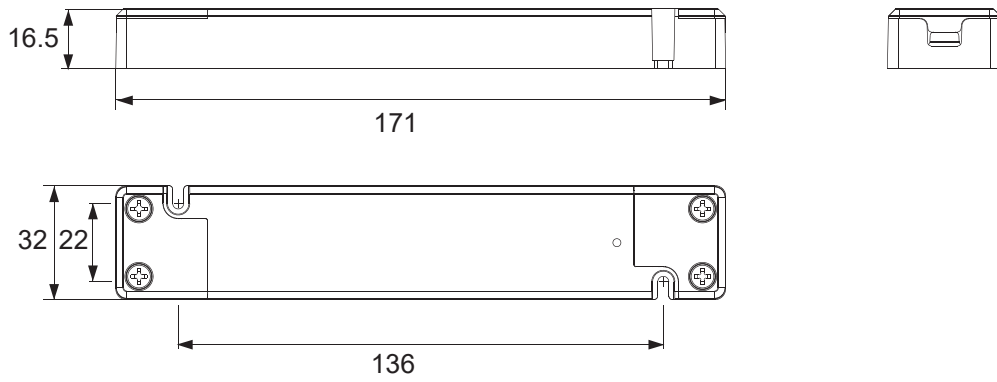

Wiring diagram:

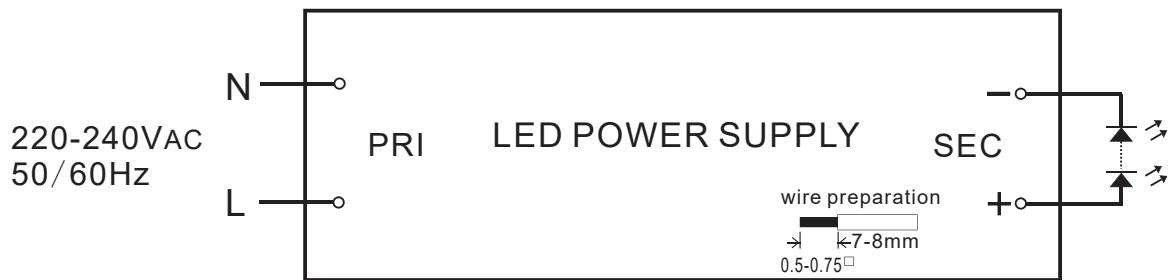

## MCBS information (Pending):

Miniature circuit breaker Model	B10	B13	B16	B20	C10	C13	C16	C20
SLT30-12VFG-EU	26	35	44	55	46	55	75	92
SLT30-24VFG-EU	26	35	44	55	46	55	75	92

## Sales & Technical Support:

### SELF Electronics Co.,Ltd.(Headquarters)

Add: No. 1345 JuXian Road,Ningbo Hi Tech Park, Ningbo,China 315103  
 Phone: +86-574-2880-5765, +86-574-2880-5658 (for English assistance)  
 +86-574-2880-5678 (for Chinese assistance)  
 Fax: +86-574-28805656  
 E-mail: sales@self-electronics.com  
<http://www.self-electronics.com>

### SELF Electronics Co.,Ltd.,Shenzhen Office

Add: Room2007, Xinglang Xuan, Xinghemingju, Fuming Rd.,  
 Futian District, Shenzhen  
 Tel: +86-755-8355-8850  
 Fax: +86-755-8355-8840  
 E-mail: szsales@self-electronics.com

### SELF Electronics Germany GmbH

August-Horch-Str. 7,51149 Cologne  
 Phone: +492203-18501-0  
 Fax: 492203-18501-199  
 E-mail: saleseu@self-electronics.com