

**KEY FEATURES**

- Switching Power Module for PCB Mountable
- 4000VAC Input to Output 2MOPP Insulation
- Cooling by Free Air Convection
- High Efficiency up to 90%
- With P.F.C. Function >0.9
- <0.3W No Load Input Power
- Screw Terminal for Option
- EMI for Both Class I (with PE) and Class II (without PE) Configuration
- Suitable for BF Application with Appropriate System Consideration
- UL / IEC / EN 60601 3.1 Edition Safety Approvals
- 3-Year Product Warranty



**ELECTRICAL SPECIFICATIONS**

All specifications valid at 230VAC input voltage, full load and +25°C after warm-up time unless otherwise stated.

Model No.	MQCS100-12S	MQCS100-24S	MQCS100-48S	
Max Output Wattage (W)	100 W			
Input	Voltage (Note 3)	90-264 VAC		
	Frequency (Hz)	47-63 Hz		
	Current (Full load)	< 2.0 A max. (115 VAC) / < 1.0 A max. (230 VAC)		
	Inrush Current (<2ms)	< 40 A max. (115 VAC) / < 70 A max. (230 VAC)		
	Leakage Current	< 0.1mA / 264 VAC (Touch Current)		
	Power Factor	PF>0.97 (115 VAC) / PF>0.9 (230 VAC) at Full Load		
Output	Voltage (V.DC.)	12V	24V	48V
	Trim	±10% Output Voltage		
	Voltage Accuracy	±2%		
	Current (A) max	8.333	4.167	2.083
	Line Regulation	±1%		
	Load Regulation (10-100%)	±1%		
	Minimum Load	0%		
	Maximum Capacitive Load	3000µF	1500µF	500µF
	Ripple & Noise (max.) (Note 1)	160mV	1% Vout	
	Efficiency (at 230VAC)	90%	90%	90%
Hold-up Time (at 115 VAC) (Note 2)	10 ms min.			
Protection	Over Power Protection	Auto recovery, Hiccup mode		
	Over Voltage Protection	Auto recovery, Hiccup mode		
	Overt Temperature Protection	Latch off		
	Short Circuit Protection	Protection level 1 (nominal) : Continuous, Auto recovery Protection level 2 (instantaneous high current) : Latch		
Isolation	Input-Output	4000VAC or 5656VDC		
	Input-FG	2000VAC or 2828VDC		
	Output-FG	1500VAC or 2121VDC		
Environment	Operating Temperature	-30°C...+70°C (with derating)		
	Storage Temperature	-30°C...+85°C		
	Temperature Coefficient	±0.05%/°C		
	Altitude During Operation	5000m		
	Humidity	95% RH		
	Atmospheric Pressure	56 kPa to 106 kPa		
	MTBF	>250,000 h @ 25°C (MIL-HDBK-217F, Notice 1)		
	Shock	IEC60068-2-27		

**ELECTRICAL SPECIFICATIONS**

All specifications valid at 230VAC input voltage, full load and +25°C after warm-up time unless otherwise stated.

Model No.	MQCS100-12S	MQCS100-24S	MQCS100-48S
Physical	Dimensions (L x W x H)		
	3.3 x 2.3 x 1.38 Inches ( 83.9 x 58.5 x 35.0 mm ) Tolerance ±0.5 mm		
	Weight		
Cooling Method			Free convection
Safety	Approval		
UL / IEC / EN 60601 3.1 <sup>rd</sup> Edition (2 x MOPP)			
EMC	Conducted EMI (Note 4)	EN55011 Conducted Class B	
	Radiated EMI (Note 4)	EN55011 Class I class B / Class II class A	
	EMS	EN60601-1-2 4th edition	

**NOTE**

- Ripple & Noise are measured at 20MHz of bandwidth with 0.1uF & 47uF parallel capacitor.
- Hold-up Time measured at 90% Vout.
- Please check the derating curve for more details.
- Please secure the power supply unit to your metal case by using the four screw holes in the corners for either Class I or Class II equipment
- CAUTION: Double pole, neutral fusing. Disconnect mains before servicing.**  
**(ATTENTION : 2 poles avec fusible sur le neutre. Deconnecter le secteur avant intervention.)**
- Please refer to our PDF file "AC-DC Application" on our website: [www.archcorp.com.tw](http://www.archcorp.com.tw)

**DERATING**

If the input voltage is below 99VAC, we can only use it under the environment of higher than -10 celsius degree

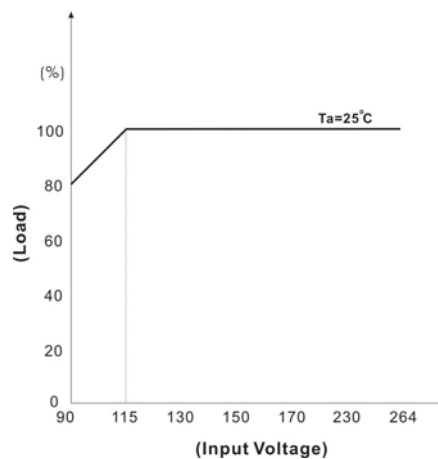
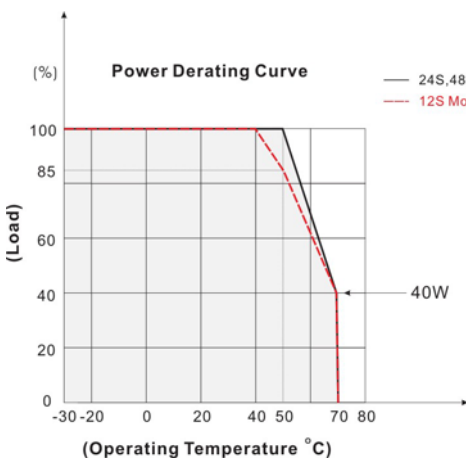



**MQCS100 SERIES**

**100 Watts**

**MECHANICAL DIMENSIONS ( Top View )**

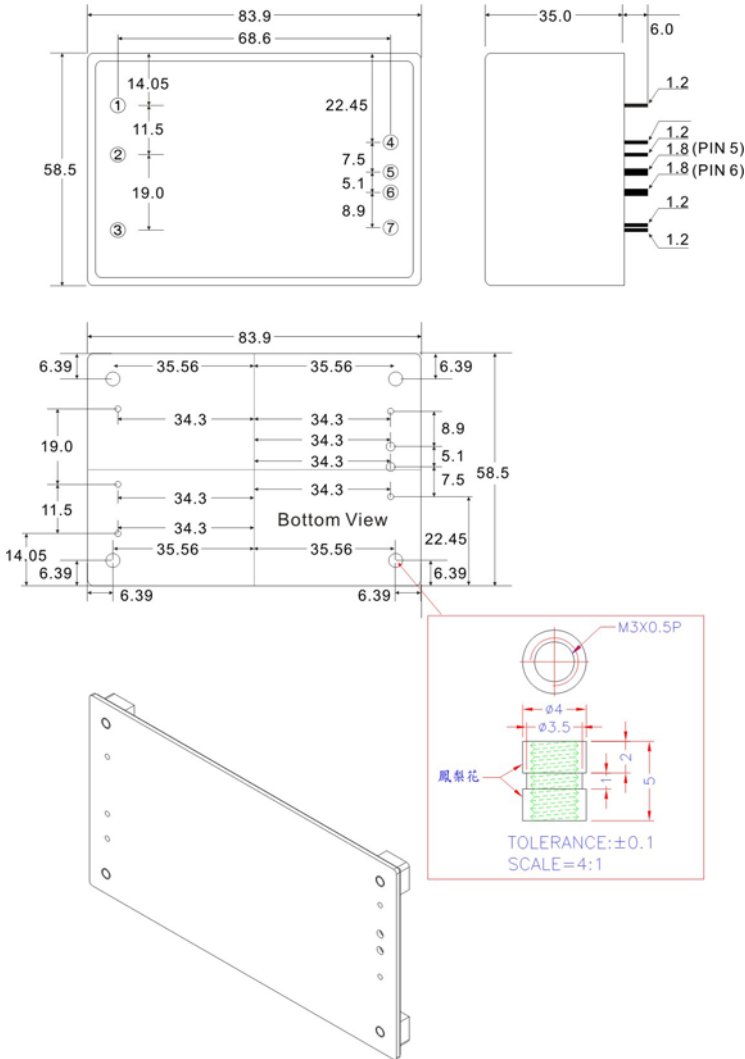

PIN#	Φ	Single
1	1.2±0.1%mm	PE
2	1.2±0.1%mm	AC IN (N)
3	1.2±0.1%mm	AC IN (L)
4	1.2±0.1%mm	ON / OFF
(Provide +5Vdc Controlled)		
5	1.8±0.1%mm	+DC OUT
6	1.8±0.1%mm	-DC OUT
7	1.2±0.1%mm	Trim

**Remark:**

Please reserve the pin 4 hole on PCB.

If the remote on/off function is not required, please connect the pin 4 circuit layout with pin6, or keep pin 4 floating.

**BLOCK DIAGRAM**

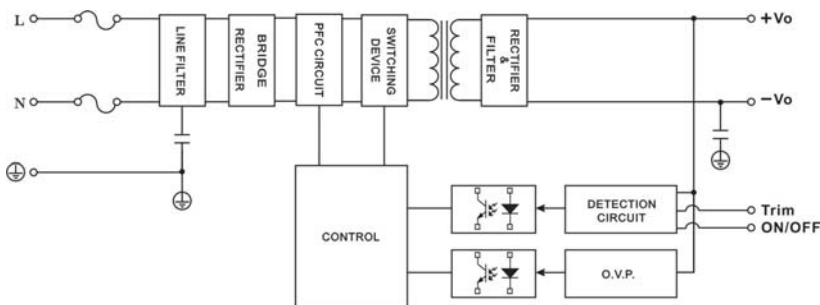

**TRIM**

	12S		24S		48S	
Trim → -V	+10%	0%	+10%	0%	+10%	0%
	16KΩ	~ 10M	17KΩ	~ 10M	20KΩ	~ 10M
Trim → +V	0%	-10%	0%	-10%	0%	-10%
	10M	~ 45KΩ	10M	~ 125KΩ	10M	~ 280KΩ

**MQCS100 SERIES**

**100 Watts**

**SCREW TERMINAL**

**MQCS100-A2**



PIN#	Single
1	PE
2	AC IN (N)
3	AC IN (L)
4	NC
5	ON / OFF
6	+DC OUT
7	-DC OUT
8	Trim

