



MPM-G205(-SB)(-C)

200W Medical AC / DC

SPECIFICATION

For

SWITCHING POWER SUPPLY

M/N: MPM-G205(-SB)(-C)

MPM-G205(-SB)(-C)

200W Medical AC / DC

Revision History

Version	Revise Date	Change Items
Rev. 01	Mar. 13. 2012	Established.
Rev. 02	Sep. 20. 2012	Revised peak load specification.
Rev. 03	Oct. 5. 2012	Added performance curves.
Rev. 04	Jun. 21. 2013	Updated safety approvals status.
Rev. 05	Jun. 23. 2014	Change description table and photo.
Rev. 06	Sep. 10. 2014	1. Add mechanical drawing with cover. 2. Add derating curve with cover. 3. Add UL approved.
Rev. 07	May. 21. 2015	Changed the initial setting accuracy of +5Vsb from $\pm 2\%$ to $\pm 2.5\%$.
Rev. 08	Nov. 25. 2015	1. Added "or equivalent" after "Molex" and "European". 2. Changed Molex Proposed Terminals from 5176 to 5167. 3. Added vibration test.
Rev. 09	Jan. 23. 2017	1. Added "Designed to meet IEC 60601-1-2 4th ed. EMC". 2. Changed IEC 61000-4-11 Voltage interruptions >95%, 250 cycles to C.
Rev. 10	Feb. 6. 2018	Changed form.
Rev. 11	Mar. 9. 2018	1. Added Designed to meet IEC 60601-1-2 4th ed. EMC. 2. Changed EMC and Safety Approvals.
Rev. 12	Jul. 3. 2018	Changed mechanical diagram.
Rev. 13	Nov. 6. 2018	1. Changed EMC: Immunity ESD to $\pm 15\text{KV}$ air discharge, $\pm 8\text{KV}$ contact discharge. 2. Changed EMC: Immunity Power Magnetic to 30A/m.



MPM-G205(-SB)(-C)

200W Medical AC / DC



FEATURES

- ✓ 200W forced air cooling, rated 120W and peak 200W convection cooled medical power supply.
- ✓ Industry standard 3" x 5" foot print.
- ✓ Active Power Factor Correction meets Class D.
- ✓ Adjustable output range.
- ✓ Class II construction for Home Healthcare Environmental applications.
- ✓ Also class I with optional functional ground connected.
- ✓ No-load power consumption < 0.5W (Green power design).
- ✓ Meet medical standard IEC 60601-1, EN 60601-1, UL 60601-1 type BF rated patient contact leakage current.
- ✓ Designed to meet IEC 60601-1-2 4th ed. EMC.
- ✓ Meet EMI CISPR/FCC class B.
- ✓ Optional +5Vsb & Remote on/off function.
- ✓ Optional cover kit with suffix -C order no.
- ✓ Designed to meet IEC 60601-1-2 4th ed. EMC.

Models & Ratings

Model Number	Wattage (Rated / Max)	Output Voltage		Min. Current	Rated Current	Max. Current
		V1	V2			
MPM-G205	120 W / 200 W	V1	+20 V - 24V	0 A	6 A - 5 A	8.4 A
MPM-G205-SB	120 W / 200 W	V1	+20 V - 24V	0 A	6 A - 5 A	8.4 A
		V2	+5 Vsb	0 A	0.1 A	0.1 A

Total Output Power: Max. 200W with 11.7 CFM force air cooling; rated 120W (peak 200W for 5 sec^(Note 1)) convection cooled at 50°C environment temperature.^(Note 2)

Note: 1. Peak load with convection cooled up to 200W keeps 5 seconds, please see the detail directions in below.

To boosting the output power, It shall be met the following conditions at the same time.

* The peak load shall not over the specified value.

* The duration of peak load shall less than 5 seconds.

* The duty cycle shall been met the following formula.

* The max. ambient temp. ≤ 50°C.

2. For more detail information of performance, please see Derating Curve.

3. MAX output current can be sustained if the total power doesn't exceed 200W.

4. Model no. coding:

M P M - G 2 0 5 - Y - a a a - Z

1
 2
 3

Y =	Output number
blank	Single output
SB	Dual output (with +5Vsb & remote on/off function)

aaa =	Output Voltage
blank	+12V
aaa	Max. 3-digit Ex: 138 = +13.8V , 14 = +14V

Z =	Input Connector Type	Output Connector Type
blank	Molex Type Connector or equivalent	Molex Type Connector or equivalent
E	Molex Type Connector or equivalent	European Type Connector or equivalent

Please see the detail in Mechanical Specification .

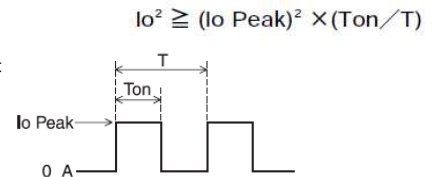

Io: Rated output current
Io Peak: Peak output current
T: Duty cycle
Ton: Duration of peak load.

Summary

Characteristic	Minimum	Typical	Maximum	Units	Notes & Conditions
Input Range	90	115 / 230	264	VAC	Continuous input range.
Input Frequency	47	50 / 60	63	Hz	AC input.
Efficiency	87	88		%	At input 230VAC, rated load, 0.5 hr. warm up.
Operation Temperature	-20		+70	°C	Please see the performance curves as below.
Weight		300		g	-SB model is 303g.
Dimensions	127 (L) x 76.2 (W) x 37.8 (H) mm, Tolerance +/- 0.4mm.				
EMC	EN 60601-1-2, EN 55011 / CISPR 11 & FCC Part 18, EN 61000-3-2 & EN 610003-3, EN 61204-3, IEC 61000-4-2, IEC 61000-4-3, IEC 61000-4-4, IEC 61000-4-5, IEC 61000-4-6, IEC 61000-4-8, IEC 61000-4-11				
Safety Approvals	IEC 60601-1: 2005, 3rd Edition, EN 60601-1: 2006, 3rd Edition, ANSI/AAMI ES60601-1:2005, 3rd ed. CAN/CSA-C22.2 No. 60601-1 (2008)				

MPM-G205(-SB)(-C)

200W Medical AC / DC

Input

Characteristic	Minimum	Typical	Maximum	Units	Notes & Conditions
Input Voltage	90	115 / 230	264	VAC	Continuous input range.
Input Frequency	47	50 / 60	63	Hz	AC input.
Input Current			2.5	A	Nominal AC Input Voltage (115VAC/230VAC), rated load.
Inrush Current			30 / 60	A	Nominal AC Input Voltage (115VAC/230VAC), one cycle at 25°C.
Leakage Current		100 / 300		μA	Primary to Secondary Normal Condition / Single Fault Condition
		100 / 300			Primary to Earth GND ^(Note 1) Normal Condition / Single Fault Condition
No-load power consumption			< 0.5	W	Nominal AC Input Voltage (115VAC/230VAC).
Power Factor	0.9				AC Input Voltage 230 VAC, rated load.
Input Protection	Dual non-user serviceable internally located AC input line fuse. Fuse : 3.15A / 250VAC * 2pcs				

Note:

1.Only exists when earth ground is connected.

Output

Characteristic	Minimum	Typical	Maximum	Units	Notes & Conditions
Output Voltage		+20 V - 24V		DC	
		+5Vsb			
Initial Set Accuracy		±1 ^(V1) ±2.5 ^(V2)		%	Initial Setting Accuracy is at Input 115VAC and all output at 60% rated load.
Minimum Load		0		A	
Start Up Delay		1.0		Sec	Time required for initial output voltage stabilization, at 230VAC Input, rated load.
Hold Up Time	25			mS	Nominal AC Input Voltage (115VAC), rated load.
Line Regulation		±1.0 ^(V1) ±1.0 ^(V2)		%	Less than ±1% at rated load with ±10% changing in input voltage.
Load Regulation		±1.0 ^(V1) ±2.0 ^(V2)		%	Measured from 60% to 100% rated load and from 60% to 20%rated load (60% ±40% rated load).
Ripple & Noise		200 - 240 ^(V1) 100 ^(V2)		mV	Measured at rated road by a 20MHz bandwidth limited oscilloscope and the each output is connected with a 10μF Electrolytic Capacitor and a 0.1μF Ceramic Capacitor.
Overvoltage Protection	For some reason the power supply fails to control itself, the build-in over voltage protection circuit will shut down the outputs to prevent damaging external circuits.				
Over Temperature Protection	When the power supply operating over the temperature or over load limit, the power supply will be shut down automatically to protect itself.				
Short Circuit Protection	Fully protected against output overload and short circuit. Automatic recovery upon of overload condition.				
Remote on/off (optional)	The power supply will be turned on when the power On/Off pin is connected to secondary GND. This function exists only with optional +5Vsb, model no. suffix "-SB".				

MPM-G205(-SB)(-C)

200W Medical AC / DC

General

Characteristic	Minimum	Typical	Maximum	Units	Notes & Conditions
Efficiency	87	88		%	At input 230VAC, rated load, 0.5 hr. warm up.
Isolation	IP to OP	4000		VAC	
	IP or OP to Ground	1500		VAC	
Switching Frequency		<65		KHZ	

Environmental

Characteristic	Minimum	Typical	Maximum	Units	Notes & Conditions
Low temperature start up	-40			°C	The unit can start-up at -40°C.
Operating Temperature	-20		+70	°C	Please see the performance curves as below.
Storage Temperature	-40		+85	°C	
Relative Humidity	5		95	%RH	Non-condensing.
Cooling	11.7			CFM	Forced-cooled when 120W~ 200W.
Operating / Non-operating Altitude		4000		m	
Vibration	0.26		6.09	G	Frequency Type: Sweep Frequency Frequency Range: 10~55 Hz Displacement: 1.0mm Sweep Rate: 60 minute / cycle Number of cycle: 1 cycle / axis Direction: X ,Y and Z axis



MPM-G205(-SB)(-C)

200W Medical AC / DC

Derating curve

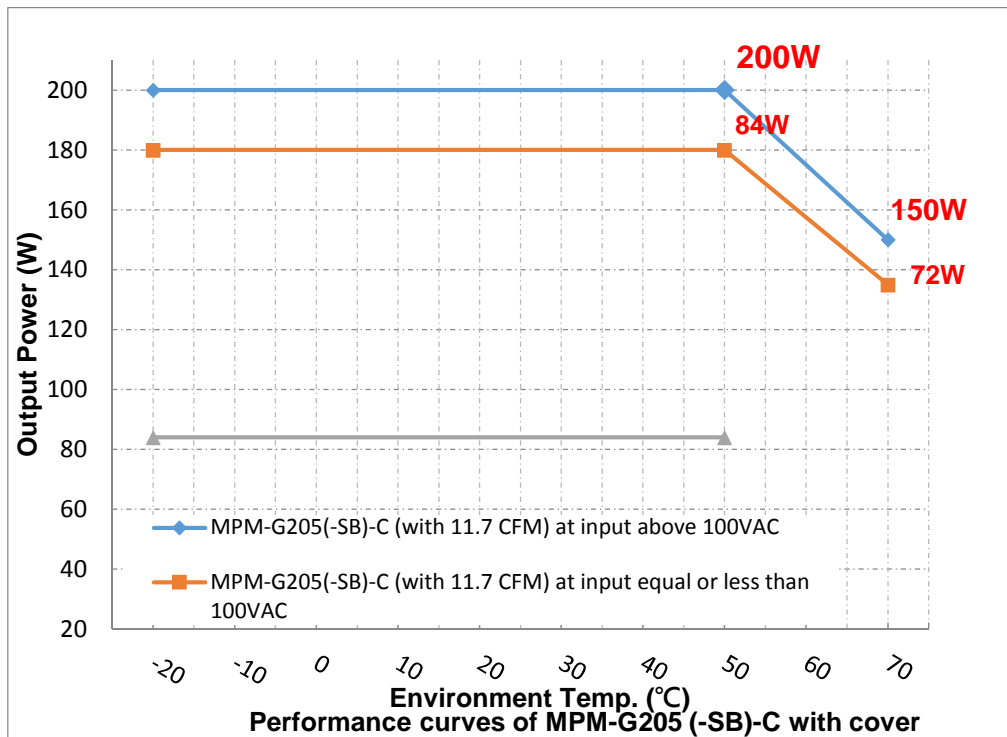
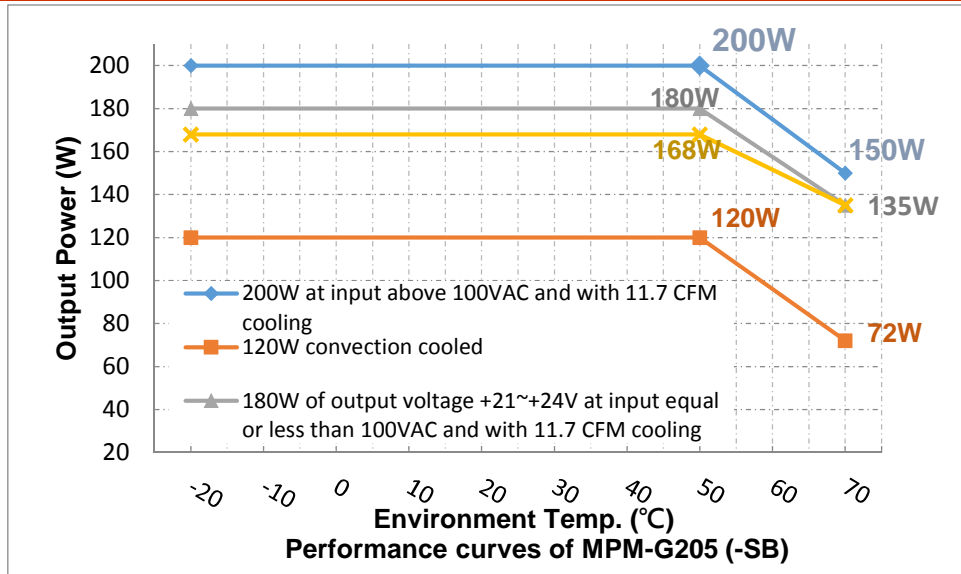



MPM-G205(-SB)(-C)

200W Medical AC / DC

EMC: Emissions

Phenomenon	Standard	Class	Notes & Conditions
Conducted	EN 60601-1-2, EN 55011 / CISPR 11 & FCC Part 18	B	
Radiated	EN 60601-1-2, EN 55011 / CISPR 11 & FCC Part 18	B	
Harmonic Current	EN 61000-3-2	D	
Voltage Flicker	EN 61000-3-3	D	

EMC: Immunity

Phenomenon	Standard	Criteria	Notes & Conditions
ESD	IEC 61000-4-2	A	±15KV air discharge, ±8KV contact discharge
Radiated	IEC 61000-4-3	A	10V/m, 80 - 2700MHz
EFT	IEC 61000-4-4	A	±2KV Line & PE, 100KHz
Surges	IEC 61000-4-5	A	L-N:±1KV, L/N-PE:±2KV
Conducted	IEC 61000-4-6	A	10Vrms
Power Magnetic	IEC 61000-4-8	A	30A/m
Dips and Interruptions	IEC 61000-4-11	A A A / B C	DIP: >95%, 0.5 cycle DIP: 30%, 25 cycles DIP: 60%, 5 cycles ^(Note 4) INT: >95%, 250 cycles

Note:

- As a build-in type power supply, the power supply needs to be installed in a suitable enclosure to pass the EMI/EMC tests. The final assembly has to comply with the valid EMI/EMC and safety.
- The mounting holes should be connected to each other to conform the EMI limit.
- Apply to output equal or below 120W. For higher output power, please re-confirm with MAGIC POWER.
- The test result of input 240Vac / 100Vac is criteria A / B.

Safety Approvals

Safety Agency	Safety Standard	Notes & Conditions
TUV	EN 60601-1: 2006, 3rd Edition	Designed to meet.
CB	IEC 60601-1: 2005, 3rd Edition	Approved.
UL/cUL	ANSI/AAMI ES60601-1:2005, 3rd ed. CAN/CSA-C22.2 No. 60601-1 (2008)	Approved.



MPM-G205(-SB)(-C)

200W Medical AC / DC

Mechanical Details

MPM-G205(-SB)

SIZE : 127.0(L) x 76.2(W) x 37.8(H)mm, Tolerance +/-0.4mm.

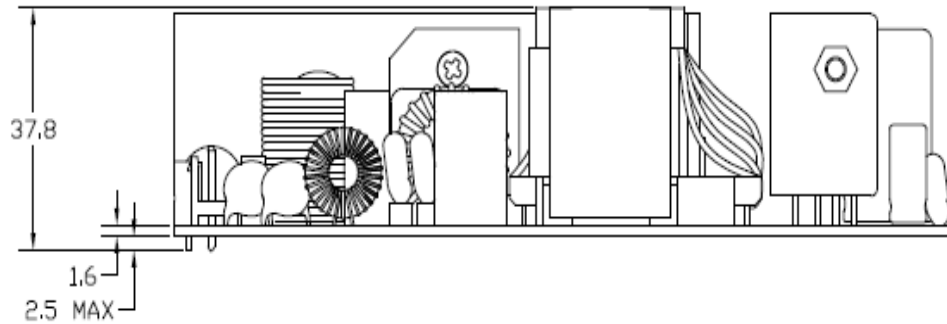
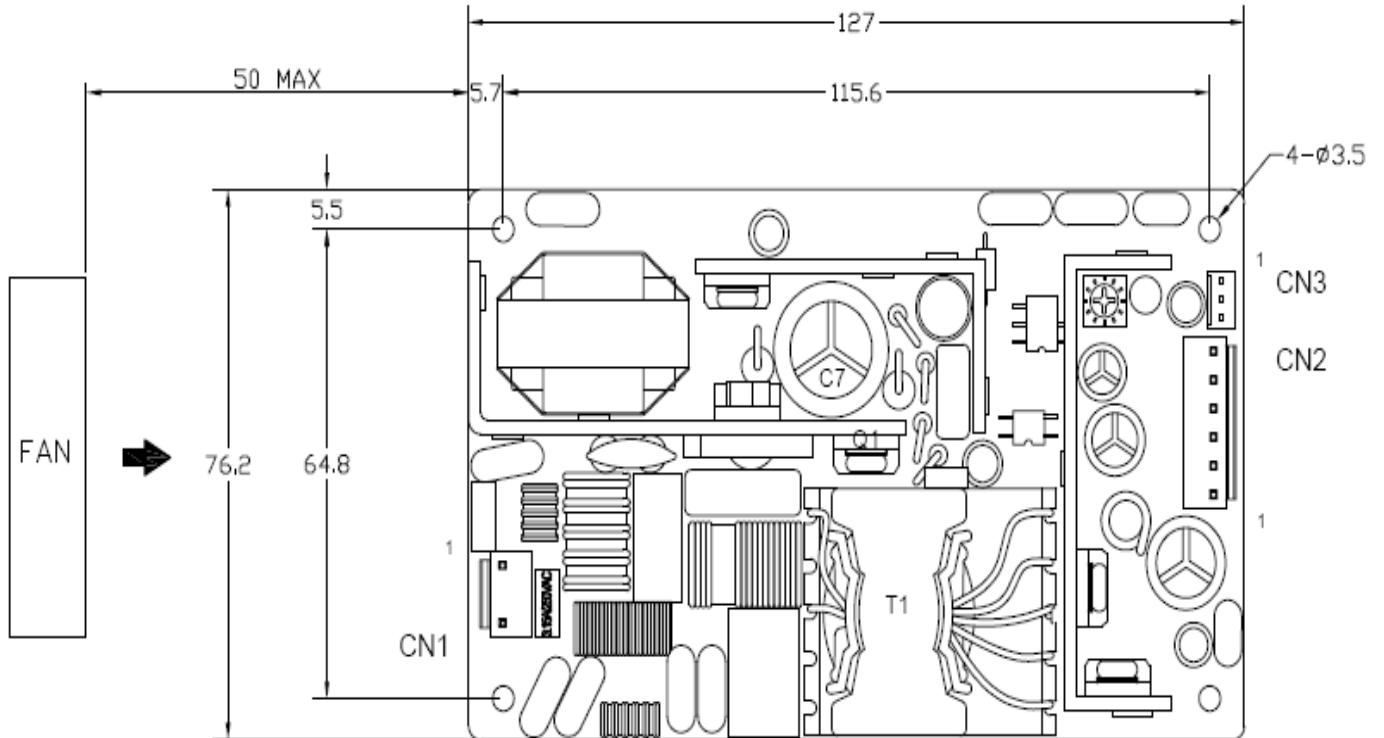



MPM-G205(-SB)(-C)

200W Medical AC / DC

MPM-G205(-SB)-C

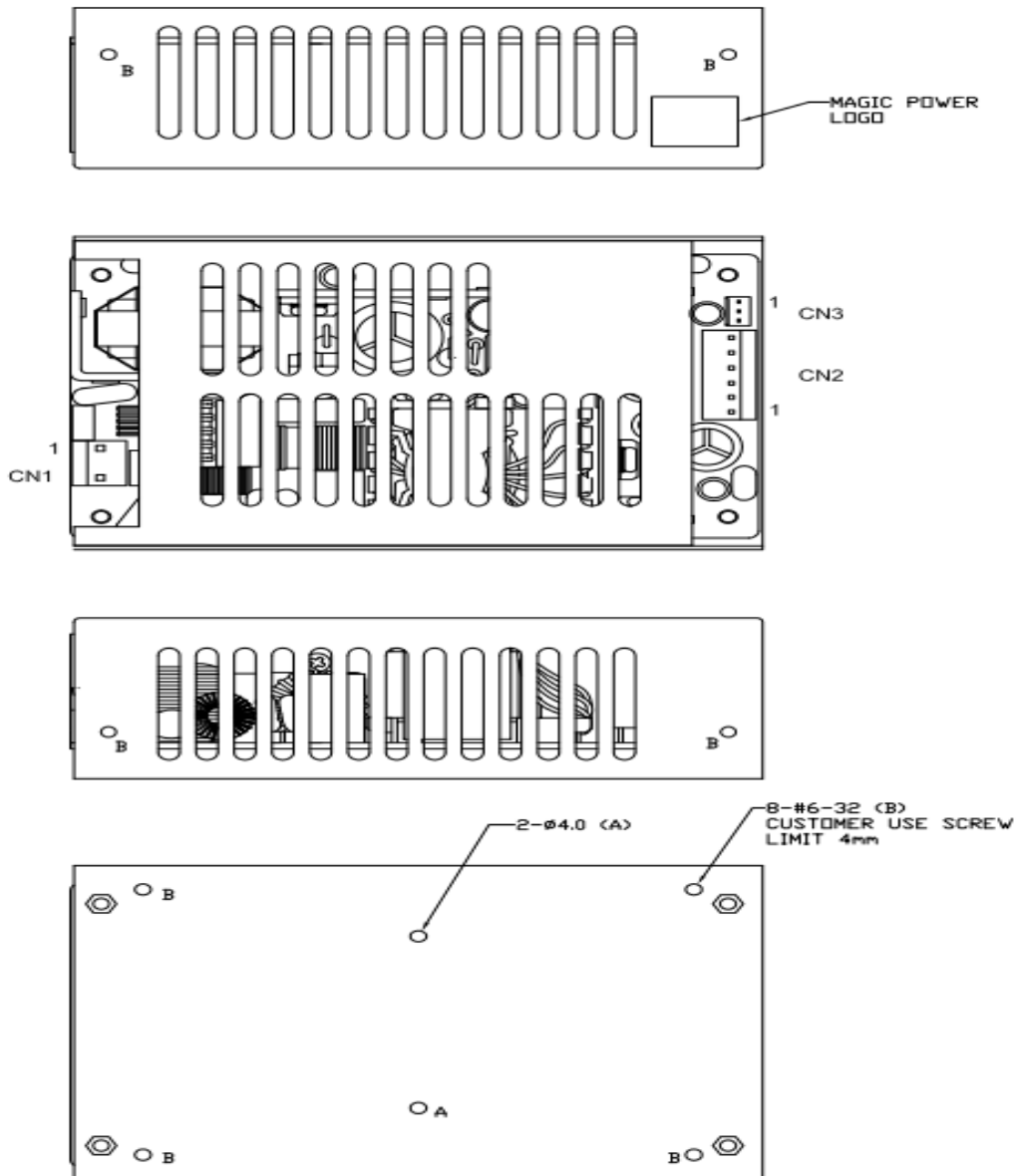

Parameter	Conditions/Description				
Dimension	127 (L) x 76.2 (W) x 37.8 (H) mm, Tolerance +/- 0.4mm.				
Connector & Pin Assignment	Location	Pin	Assignment	Proposed Housing	Proposed Terminals
	CN1 (Input)	1	AC in (L)	MOLEX: 09-50-1031 (5195-03) or 09-52-4034 (5239-03) or equivalent;	MOLEX: 5194 or 5225 2478, 2578,5167 or 5168 or equivalent;
2		AC in (N)			
CN2 (Output)	1	+ V	MOLEX: 09-50-1061 (5195-06) or 09-52-4064 (5239-06) or equivalent; European type: MOLEX / 39523-7004 or Dinkle / ESD series (Note 1) or equivalent	MOLEX: 5194 or 5225 2478, 2578,5167 or 5168 or equivalent; European type: N/A (Note 1)	
	2	+ V			
	3	+ V			
	4	0 V			
CN3 (Option) (Note 2)	5	0 V	MOLEX: 22-01-1032 (5051-03) or 51191-0300 or equivalent;	MOLEX: 2759 or 5159 50802 or equivalent;	
	6	0 V			
	1	+5Vsb			
	2	0 V			
	3	Remote On/off			

Note:

- Exist with model no. suffixed -E, the pin assignment of CN2 is Pin 1-2 for + V, Pin 3-4 for - V; please also refer to the comparison in Model no. coding.
- Exist with model no. suffixed -SB, please see the detail in Model no. coding



MPM-G205(-SB)(-C)

200W Medical AC / DC

Thermal Considerations

In order to ensure safe operation of the PSU in the end-use equipment, the temperature of the components listed in the table below must not be exceeded.

Temperature should be monitored using J type thermocouples placed on the hottest part of the component (out of any direct air flow). See Mechanical Details for component locations.

Temperature Measurements at max. amb.	
Component	Max Temperature
T1	110°C
Q1	120°C
D5, D6	120°C
C7	105°C
C21	105°C