

DC-DC CONVERTER HFBC30-xxW/O

RAILWAY CONVERTER.

FOR CHASSIS MOUNTING



HIGHLIGHTS

- + Output Power up to 33 Watts*
- + Ultra Wide Input Range
- + Wide Temperature Range
- + Hold-up-time > 10ms
- + RoHS compliance
- + According to EN50155

INPUT

Input Voltage Nominal	24, 36, 48, 72 and 110 VDC
Input Voltage Operating	16,8-138 VDC
Input Voltage Range	14,4-154 VDC ($t \leq 1,0$ sec.)
No Load Input Current	See table page 2
Internal Fusing	3,15 AT

OUTPUT

Output Voltage	5,1 V / 12 V
Initial Set Accuracy	< 1 % (no load)
Minimum Load	No minimum load
Short circuit	Continuous short circuit proof
Line Regulation	< 0,5 %
Load Regulation	< 1 % (0% - 100% load)***
Ripple & Noise	< 1 % pk-pk, 20 MHz bandwidth
Start Time	< 250 ms
Max. Output Capacitance	500 μ F x $I_{out, nom}$
Temperature Coefficient	< 0.01 %/°C (V_{out1} and V_{out2})

FEATURES

Enable Signal Primary	EN connected to Vin+: ON; EN open or connected to Vin-: OFF.
Active Reverse Polarity Protection	Max. 160 V
Active Inrush Current Limitation	Max. 5 A
Hold-up-time	> 10 ms (typ. 15 ms) at full load
Input Power Fail Signal	Isolated Output. Active Level: Low
Thermal Warning Signal	Isolated Output. Active level: Low T=70-75°C PCB with 5°C hysteresis
Power Good Signal	Open-collector Output

PROTECTION

Output Over Voltage Protection (OVP)	110-130 % $V_{out, nom}$ (output 2 latched, reset through EN or power off)
Over Current Protection (OCP)	See table page 2
Over Temperature Protection (OTP)	Shutdown at +100-105°C PCB-temp. with 5°C hysteresis and auto recovery.

GENERAL

Product Standard	EN 50155:2007
Isolation	2200 VDC Input to Output 1500 VDC Input to Earth (PE) 710 VDC Output to Earth (PE)
Switching Frequency	Typ. 100 / 135 / 260 kHz****
Dimensions [mm]	120 x 100 x 28
Weight	approx. 180 g
MTBF	1.400.000h acc. to IEC/TR 62380 (40°C)

ENVIRONMENTAL

Operating Ambient Temp.	-40°C to +85°C*
Operating PCB Temp.	-40°C to +100°C
Storage Temperature	-40°C to +100°C
Vibration / Shock / Bump	EN 61373:1999, Cat. 1B

EMC

EMC Standard	EN 50121-3-2:2006
Conducted Emissions	EN 55011:2007+A2:2007, Class A**
ESD Immunity	EN 61000-4-2 :1995+A1 :1998+A2 :2001, level 3 (6kV/8kV), Criteria A
Burst	EN 61000-4-4:2004, level 3 (2kV), Criteria A
Surge	EN 50121-3-2:2006, line to line \pm 1kV, 42R, and line to case \pm 2kV, 42R, Criteria B
Conducted Immunity	EN 61000-4-6:2007+A1:2001, level 3 (10V), Criteria A

* +70°C continuously, +85°C max. 10 minutes. With additional thermal conductive pads between PCB and heat sinking mounting surface at free convection in vertical position.

** In built-in condition the devices may show different EMC properties.

*** Value could be higher, depending on the voltage drop of the connector.

**** Booster / Converter / Step-down

TECHNICAL DATA

For $T_{amb} = 25^{\circ}\text{C}$, $V_{in\ nom}$, $I_{out\ nom}$, unless otherwise specified

SPECIFICATION Input 14,4 - 154 VDC

TYPE		HFBC30-2DW/O					
ORDER NUMBER		87 63 65 0112 3 connector horizontal					
		87 63 65 0113 7 connector vertical					
CHARACTERISTIC		Unit					
INPUT	Input Voltage Nominal	V	24	36	48	72	110
	Input Voltage Range	V	14,4...36	21,6...51	28,8...67,2	43,2...101	66...154
	Under Voltage Turn-on	V	<16,8				
	Under Voltage Turn-off	V	<14,4 (14,4V < Vin < 16,8V at t > 1 sec.)				
	Input Current @ Full Load	A	1,75	1,1	0,85	0,55	0,35
	Input Current @ No Load*	A	0,128	0,085	0,065	0,043	0,028
	Input Current disabled mode	mA	9	6,5	5,5	4,5	4,5
OUTPUT			Output 1		Output 2		
	Output Voltage Nominal	V	5,1		12		
	Output Current Nominal	A	4		1...2,75***		
	Output Power	W	20		33***		
	Efficiency @ Full Load (typical)	%	80	82	83,5	84	85
	Output Current limit	A	5,0...5,5		1,9...3,9***		
	Short Circuit Current (typical)	A	4,8		5 (pulse approx. 8 Hz)**		
Transient Response 25 % / 75 % Load Step Recovery Time < 1 ms	mV	±50		±120			

* Enable Primary on

** Peak current pulsating

*** Power Distribution with V_{out1}

TECHNICAL DATA

For $T_{amb} = 25^{\circ}\text{C}$, $V_{in\ nom}$, $I_{out\ nom}$, unless otherwise specified

MECHANICAL DETAILS

- Dimensions in mm
- Unless otherwise specified, general tolerances $\pm 0,5$ are for values in brackets (XX).
Values not in brackets are according to ISO 2768-1m.

Coating: Lackwerke Peters ELPEGUARD SL 1307-FLZ/342

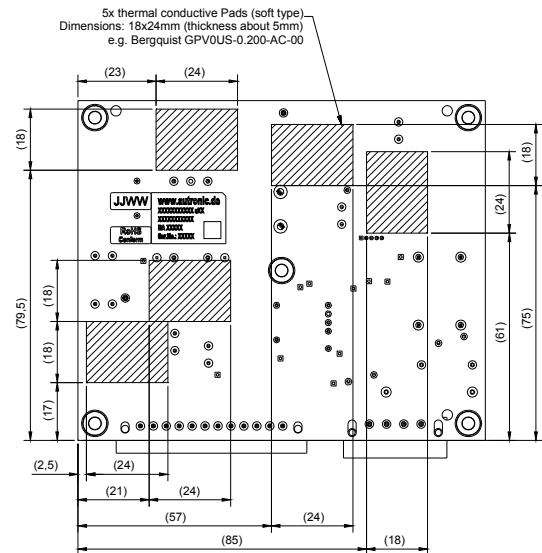
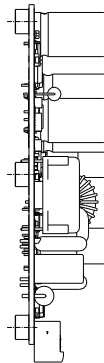
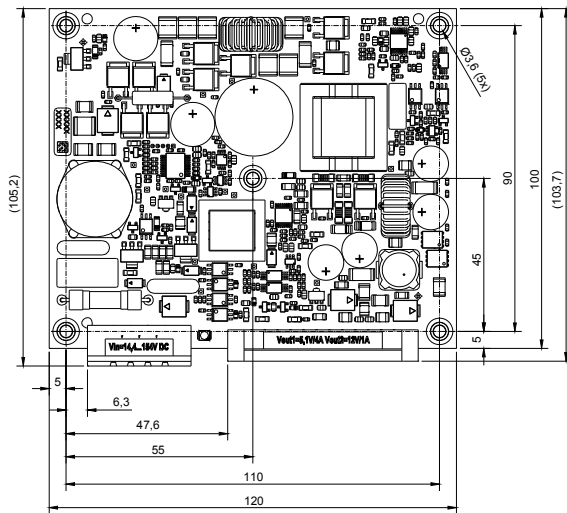
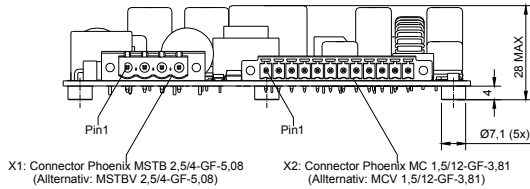

PINNING

Pin	Function	Pin	Function
X1-1	V_{in-}	X2-1	+Input Power Fail
X1-2	V_{in+}	X2-2	-Input Power Fail
X1-3	Enable Primary (EN)	X2-3	Internal Connected
X1-4	Case (PE)	X2-4	Internal Connected
		X2-5	+Thermal Warning
		X2-6	-Thermal Warning
		X2-7	Power Good (PG)
		X2-8	GND (0V)
		X2-9	V_{out1} (5V)
		X2-10	GND (0V)
		X2-11	V_{out2} (12V)
		X2-12	GND (0V)

NOTES

Installation instructions:

The converters have to be installed according to the guidelines currently in force, like other open electronic component assemblies. Attention must be paid to sufficient ventilation, carry off heat, fastening and protection against accidental contact. Additional thermal conductive pads might be necessary to get a thermal coupling to the mounting-surface. The mounting surface must be flat and able to remove the thermal energy of the PCB (PCB temperature must not exceed $+100^{\circ}\text{C}$).

Fault protection:

The converters are equipped with a soldered-in-time-lag fuse corresponding to IEC 60127-2 for input protection. In case at fault the supplying current source must be capable to blow the fuse.

BLOCK DIAGRAM

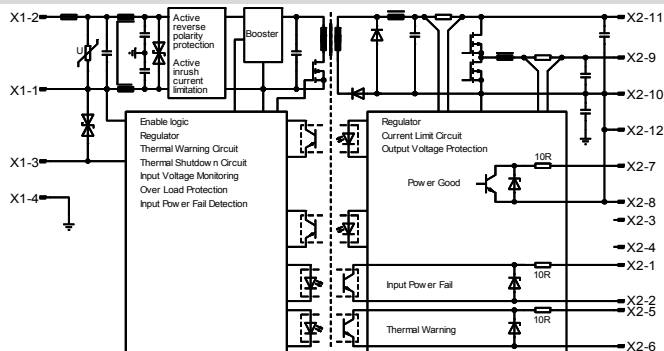

DESCRIPTION OF FEATURES

For $T_{amb} = 25^{\circ}\text{C}$, $V_{in\ nom}$, $I_{out\ nom}$, unless otherwise specified

ENABLE SIGNAL PRIMARY

If the Enable Signal is activated, the converter starts operating.

Enable Primary (X1-3) is activated by a voltage between 10 VDC and 160 VDC referenced to V_{in-} (X1-1).

Typically it is directly switched to V_{in+} to enable the converter. The pin sinks about 1,7 mA.

INPUT POWER FAIL SIGNAL

The Input Power Fail is a potential-free open-collector output realized by an optocoupler. Maximum current = 5 mA, maximum voltage = 20 V, saturation voltage < 1,2 V. The Input Power Fail becomes active when the input voltage < 16,8 V. Input Power Fail could be provided, to inform the system about power loss, for a safe shutdown while the hold-up-time is running.

THERMAL WARNING SIGNAL

The Thermal Warning is a potential-free open-collector output realized by an optocoupler.

Maximum current = 5 mA, maximum voltage = 20 V, saturation voltage < 1,2 V.

The Thermal Warning becomes active when the temperature of the PCB rises above typ. 75°C , with a hysteresis of about 5°C .

POWER GOOD SIGNAL

The Power Good is an open-collector output to inform the system if the output voltages are under 95 % of $V_{out\ nom}$.

OVER CURRENT PROTECTION

The output power of the converter is limited to about 40 W. The power is distributed to the both output voltages, 12 V and 5 V.

The main output is 12 V and can carry up to 2,75 A continuously. At overload and current limit, the voltage decreases down to 8 V, then the converter switches-off and tries to restart after 100 ms. Out of the 12 V, the 5 V output is made. It has a nominal current of 4 A and current limit of about 5 A. If 12 V switches-off, 5 V goes down, too.

On request:

STATUS LED

Between the two connectors a LED can be activated, to show internal states or errors with a customer specific blinking code. The functionality is user-configurable with the integrated microprocessor.

SECONDARY STANDBY VOLTAGE

Instead of the Power Good Signal a standby voltage of 5 V can be realized on X2-7, independent of the status of the converter. When the input voltage is above 15 V, the auxiliary power supply starts. The standby voltage is on the same potential as the other outputs. This output can carry load up to 75 mA, has a current limit at about 150 mA and is short circuit proof.

ENABLE SIGNAL SECONDARY

Enable Secondary can be realized as a potential-free-input on (X2-3 / X2-4) with a voltage between 3 VDC and 12 VDC to activate the signal.

APPLICATION NOTES

For $T_{amb} = 25^{\circ}\text{C}$, $V_{in\ nom}$, $I_{out\ nom}$, unless otherwise specified

DERATING

Derating above 37°C without thermal conductive pads.
Derating factor between 37°C and 85°C : 0,5 W/K.