



Technical Information

DP2420

Product name
DP2420



Description	DP2420
	The DP2420 is among the flattest industrial power supplies in its class. To meet the requirements of maritime applications, the product has been designed according to the most important industrial and maritime (Lloyd's Register) safety standards. Other features include compliance with IEC/EN 61000-3-2, Class A harmonic current, integrated DC-OK contacts and an LED to indicate DC-OK and overload conditions. The DP2420 has a power boost of 150% up to 7 seconds, and is equipped with Advanced Power Boost (APB).

Characteristics	
	Built-in constant current circuit for charging application
	Full Power from -25°C to +60°C until 5.000m
	Power Boost of 150% up to 7 seconds
	Advanced Power Boost (APB) – protect system and ensure continuing operation when large inrush current detected due to faulty load on a multiple load connection
	DNV GL and ABS approvals for maritime applications
	Built-in DC OK Contact and LED indicator for DC OK/ Overload
	Conformal coating on PCBAs to protect against common dust and chemical pollutants

Eingang		
Nominal Input Voltage	3 x 400-500 Vac	Applicable for TN-, TT and IT mains networks
Input Voltage Range	3 x 320-575 Vac (3-Phase) or 2 x 380-575 Vac (2-Phase)	Continuously operating
Nominal Input Frequency	50-60 Hz	Range: 47-63 Hz
DC-Input Voltage Range	450-800 Vdc	Fulfills the test conditions for DC input. DC input safety approval can be obtained upon request.



	400 VAC	480 VAC	500 VAC	
Input Current (typ)	0.78 A	0.67 A	0.66 A	At 24 V, 20 A
Input Current (Max.)	0.79 A	0.68 A	0.68 A	At 24 V, 20 A
Efficiency (typ)	95.23%	95.24%	95.24%	At 24 V, 20 A
Efficiency (Max.)	95.00%	94.80%	94.80%	At 24 V, 20 A
Average Efficiency	93.42%	93.21%	93.14%	At 24 V, 5 A (25%), 10 A (50%), 15,5 A (75%), 20 A (100%)
Power Dissipation (typ)	4.6 W	5.00 W	5.10 W	At 24 V, 0 A
Power Dissipation (Max.)	8.2 W	10.00 W	10.00 W	At 24 V, 0 A
Power Dissipation (typ)	16.19 W	16.67 W	16.80 W	At 24 V, 10 A
Power Dissipation (Max.)	17.50 W	18.00 W	18.00 W	At 24 V, 10 A
Power Dissipation (typ)	24.08 W	24.03 W	24.01 W	At 24 V, 20 A
Power Dissipation (Max.)	25.30 W	26.40 W	26.40 W	At 24 V, 20 A
Inrush Current (Cold Start) (typ.)	7.4 A	8.3 A	8.6 A	Entire operating temperature range
Inrush Current (Cold Start) (Max.)	10.0 A	10.0 A	10.0 A	
Max. Inrush Energy (Kaltstart)	1.0 A ² s			
Power Faktor (typ)	0.93	0.90	0.94	At 24 V, 20 A
Power Faktor (Min.)	0.39	0.90	0.90	At 24 V, 20 A
Leakage current (Enclosure to neutral)	< 0.80 mA / 0.80 mA < 1.00 mA / 1.00 mA < 1.20 mA / 1.20 mA < 1.30 mA / 1.30 mA			3x400 Vac, 50 Hz, TN/TT / IT system 3x440 Vac, 50 Hz, TN/TT / IT system 3x480 Vac, 60 Hz, TN/TT / IT system 3x528 Vac, 60 Hz, TN/TT / IT system

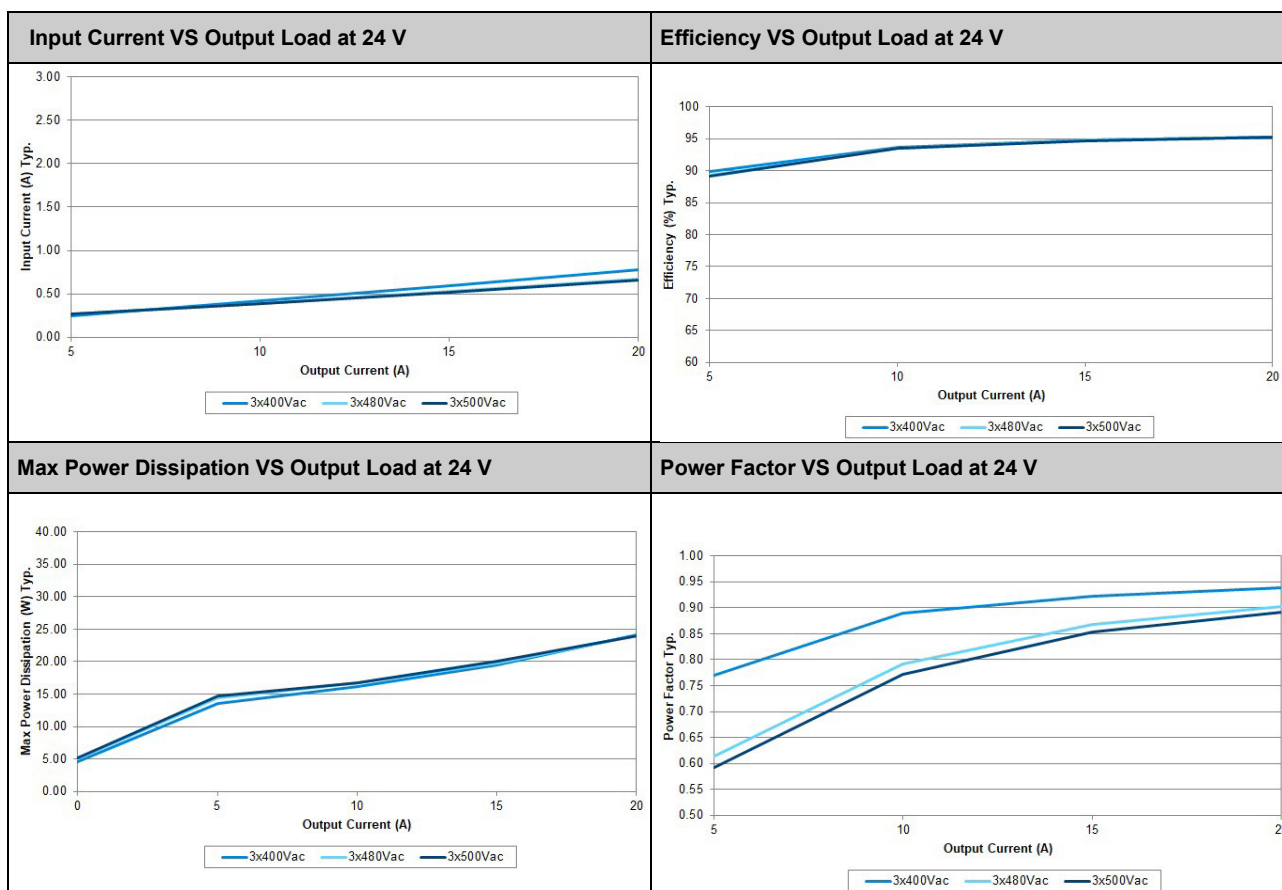



Output		
Nominal Output Voltage	24 Vdc	
Factory Set Point Tolerance	24 Vdc \pm 1.0%	
Output Voltage Adjustment Range	24-28 Vdc	
Output Current	20 A / 17.1 A 30 A / 25.65 A (slew rate 0.1 A/ μ s)	Continuously operating at 24 V / 28 V Power Boost for 5 seconds at 24 V / 28 V
Output Power	480 W / 478.8 W 720 W / 718.1 W	Continuously operating at 24 V / 28 V Power Boost for 5 seconds at 24 V / 28 V
Power Boost Duration	Typ.: 4 Sec Max.: 7 Sec	Duration after which output voltage start to droop. Refer to the details in the Function section at Overload & Overcurrent Protections
Power Boost Recovery Time	Typ.: 17 Sec	Required wait duration before next Power Boost can be delivered by the power supply
Advanced Power Boost (Slew rate 0.1 A/ μ s)	40 A @ 50 ms, resistive load 80 A @ 2 ms, resistive load 80 A @ 5 ms, resistive load	Output voltage will drop
Line Regulation	10 mV (@ 3 x 320-575 Vac input, 100% load)	
Load Regulation	100 mV (@ 3 x 320-575 Vac input, 0-100% load)	
PARD**	Max.: 100 mVpp	20 Hz to 20 MHz, 50 Ohm, warm up for 5 mins

	400 VAC	480 VAC	500 VAC
Rise Time		Max. 30 ms Max. 40 ms	0 μ F, 24 V, 20 A 20000 μ F, 24 V, 20 A
Start-up Time		Max. 500 ms	At 24 V, 20 A
Hold-up Time		Typ.: 44 ms Min.: 36 ms Typ.: 22 ms Min.: 18 ms	At 24 V, 10 A At 24 V, 10 A At 24 V, 20 A At 24 V, 20 A
Dynamic Response (Overshoot & Undershoot O/P Voltage)	\pm 5% @ 1.5-100% load		Slew rate 0.1 A/ μ s (@ 5 Hz, 50 Hz, 100 Hz & 1 kHz, 50% load)
Start-up with Capacitive Loads	20,000 μ F		
Output Capacitance	6,600 μ F		Built-in output capacitors
Functional	DC OK Relay: 30 V at 1 A, resistive load Paralleloption: yes		

Environment	
Surrounding Air Temperature	-25°C to +70°C (-40°C Cold Start), 5-95% RH (non condensing)
Storage Temperature	-40°C to +85°C
Temperature Derating (Power)	Vertical mounting: 3-phase: > 60°C derating by 2.5 % / °C 2-phase: > 60°C derating by 2.5 % / °C Horizontal mounting: 3-phase: > 40°C derating by 1.67 % / °C 2-phasic: > 40°C derating by 2.0 % / °C
Operating Altitude and Over Voltage Category	OVC III: 0 to 2500 Meters OVC II: 2500 to 6000 Meters 0 to 5000 Meters 0 to 3000 Meters According to IEC/EN 62477-1 / EN 60204-1 und IEC 62103 According to ITE, IEC/EN 61010 According to IEC/EN 61558
Shock Test	Non-operating: IEC 60068-2-27, Half Sine Wave: 30 G for a duration of 18 ms; 3 times per direction, 6 times in total
Vibration	Non-operating: IEC 60068-2-6, Sine Wave: 10-500 Hz; 3 G peak; displacement of 0.35 mm; 60 min per axis for all X, Y, Z directions
Bump Test	Operating: IEC 60068-2-29, Half Sine Wave: 10 G for a duration of 11 ms, 1,000 times per direction, 6,000 times in total
Pollution Degree	2



Protection		
Overvoltage	< 32 V, SELV Output, Hiccup Mode, Non-Latching (Auto-Recovery)	
Overload / Overcurrent	160-195% of rated load current, Constant current, Hiccup Mode (Auto-Recovery)	
Over Temperature	< 80°C Surrounding Air Temperature @ 100% load, Non-Latching (Auto-Recovery)	
Short Circuit	Hiccup Mode, Non-Latching (Auto-Recovery when the fault is removed)	Load impedance ≤ 100 Ohm
Transient Surge Voltage Protection	MOV (Metal Oxide Varistor)	
Internal Fuse	3 x T 3.15 A H	
Degree of Protection	IP20	
Protection Against Shock	Class I with PE* connection	
MTBF (Telcordia SR-332)	750,000 hrs.	I/P: 3 x 400 Vac, O/P: 24 V, 20A, Ta: 25°C
	500,000 hrs.	I/P: 3 x 400 Vac, O/P: 24 V, 20A, Ta: 40°C
Expected Cap Life Time	374,000 hrs.	I/P: 3 x 400 Vac, O/P: 24 V, 10A, Ta: 25°C
	129,800 hrs.	I/P: 3 x 400 Vac, O/P: 24 V, 10A, Ta: 40°C
	263,100 hrs.	I/P: 3 x 400 Vac, O/P: 24 V, 20A, Ta: 25°C
	92,900 hrs.	I/P: 3 x 400 Vac, O/P: 24 V, 20A, Ta: 40°C

Protection/EMC		
Electrical Equipment of Machines	EN/BS EN 60204-1 (over voltage category III)	
Electrical Equipment for Use in Electrical Power Installations	IEC/EN/BS EN 62477-1 / IEC 62103	
Safety Entry Low Voltage	SELV (IEC 60950-1)	
Electrical Safety	SIQ Bauart: EN 62368-1, EN 61558-1, EN 61558-2-16, EN 61010-1, EN 61010-2-201 UL/cUL: UL 60950-1 and CSA C22.2 No. 60950-1 (File No. E191395) UL 62368-1 and CSA C22.2 No. 62368-1 (File No. E191395) CB scheme: IEC 60950-1, IEC 62368-1, IEC 61558-1, IEC 61558-2-16, IEC 61010-1, IEC 61010-2-201 UKCA: BS EN 62368-1, BS EN 61558-1, BS EN 61558-2-16, BS EN 61010-1, BS EN 61010-2-201	
Industrial Control Equipment	UL/cUL: UL 508 and CSA C22.2 No. 107.1-01 (File No. E315355)	
Maritim	DNV GL: Germanischer Lloyd classified ABS: American Bureau for Shipping, PDA Umweltkategorie: C, EMC2	
CE	In conformance with EMC Directive 2014/30/EU and Low Voltage Directive 2014/35/EU	
UKCA	In conformance with Electrical Equipment (Safety) Regulations 2016 No. 1011 and The Electromagnetic Compatibility Regulations 2016 No. 1091	
Galvanic Isolation	4.9 KVac	Input / Output
	2.88 KVac	Input / PE
Isolation Resistance	4.90 KVac	Input / DC OK Relay Contact
	1.50 KVac	Output / PE
	0.5 KVac	Output / DC OK Relay contact
	1.50 KVac	DC OK Relay Contact/ PE
PE Resistance	> 5 MOhm	Input to Output, 500 Vdc
Emissionen (CE & RE)	Generische Standards: EN/BS EN 61000-6-3 CISPR 32, EN/BS EN 55032, CISPR 11, EN/BS EN 55011, FCC Title 47: Klasse B	
Component Power Supply for General Use	EN/BS EN 61204-3	
Immunity	Generic Standards: EN/BS EN 55024, EN/BS EN 55035, EN 61000-6-2	
Electrostatic Discharge	IEC 61000-4-2	Level 4, Criteria A, Air Discharge 15kV; Contact Discharge: 8kV
Radiated Field	IEC 61000-4-3	Level 3, Criteria A 80 MHz – 1 GHz, 10 V/M, 80% modulation (1 kHz) 1.4 GHz – 2 GHz, 10 V/M, 80% modulation (1 kHz) 2 GHz – 2.7 GHz, 10 V/M, 80% modulation (1 kHz)
Electrical Fast Transient/ Burst	IEC 61000-4-4	Level 4, Criteria A, 4kV
Surge	IEC 61000-4-5	Level 4 Criteria A, Common Mode: 4 kV Differential Mode: 2 kV



Conducted	IEC 61000-4-6	Level 3 Criteria A 150 kHz – 80 MHz, 20 Vrms
Power Frequency Magnetic Fields	IEC 61000-4-8	Criteria A, 30A/Meter
Voltage Dips and Interruptions	IEC 61000-4-11	0% of 3 x 380 Vac, 0 Vac, 20 ms, Criteria A 0% of 3 x 480 Vac, 0 Vac, 20 ms 40% of 2 x 380 Vac; 152 Vac, 200 ms, Criteria A 40% of 2 x 480 Vac; 192 Vac, 200 ms, Criteria A 70% of 2 x 380 Vac; 266 Vac, 500 ms, Criteria A 70% of 2 x 480 Vac; 336 Vac, 500 ms, Criteria A 0%; 0Vac, 5,000 ms, Criteria B
Low Energy Pulse Test IEC 61000-4-12 (Ring Wave)	IEC 61000-4-12	Level 3 Krit A, Common Mode: 2 kV; Differential Mode: 1 kV
Harmonic Current Emission	IEC/EN/BS EN 61000-3-2, Class A	
Voltage Fluctuation and Flicker	IEC/EN/BS EN 61000-3-3	
Voltage Sag Immunity SEMI F47 – 0706	80% of 380 Vac 70% of 380 Vac 50% of 380 Vac	304 Vac, 1,000 ms; Criteria A 266 Vac, 500 ms; Krit A 190 Vac, 200 ms; Krit A

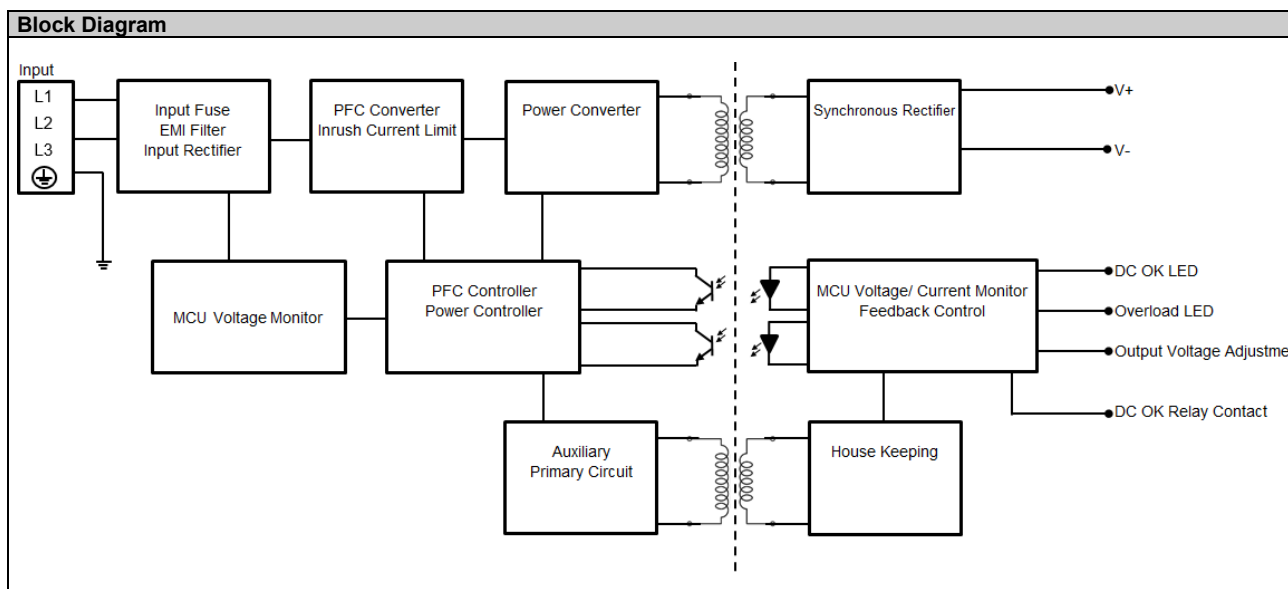



Mechanical Data

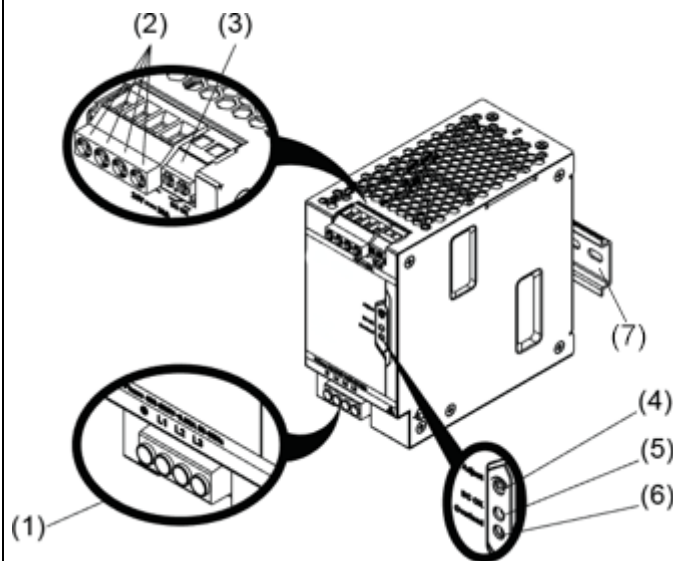

- 1) Input terminal block connector
- 2) Output terminal block connector
- 3) DC OK relay contact
- 4) DC voltage adjustment potentiometer
- 5) DC OK LED (Green)
- 6) Overload LED (Red)
- 7) Universal mounting rail system

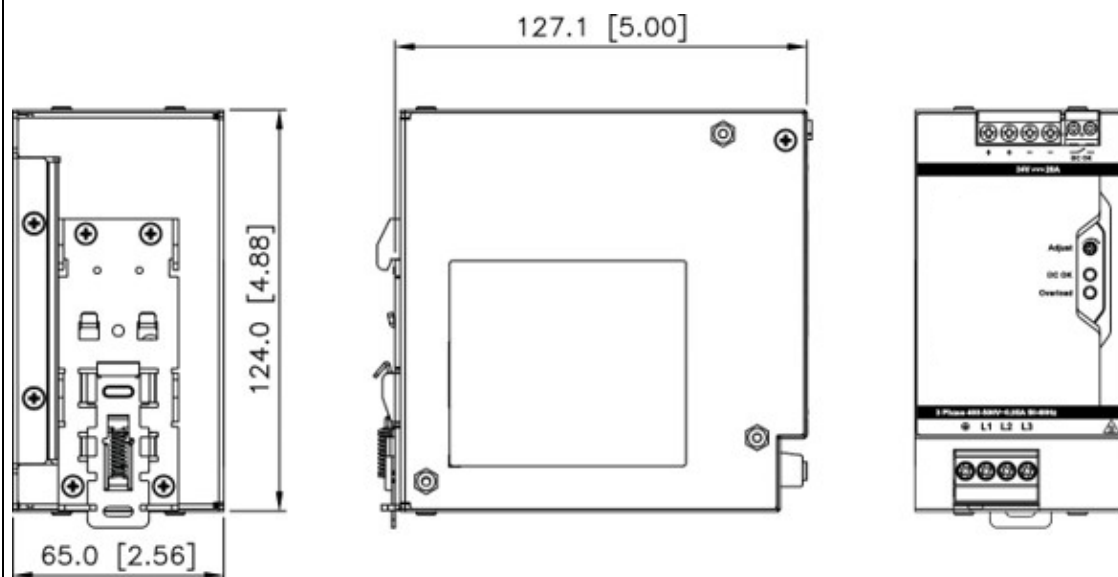

Case Cover / Chassis	Aluminium
Dimensions (L x W x D)	124 x 65 x 127.1 mm
Unit Weight	1.18 kg
Indicator	green LED: DC OK red LED: Over load
Cooling system	Konvektion
Terminal	Input 4 Pins (Rated 600 V / 35 A) 4 Pins (Rated 300 V / 30 A) 5 Pins (Rated 300 V / 28 A)
Wire	Input: AWG 18-8 Output: AWG 14-10 Signal: AWG 20-12
DIN Rail	Standard TS35 DIN-rail (after EN 60715)
Noise	Sound Pressure Level (SPL) < 25 dBA