



DC-DC Converter AVP/KE Output power up to 100 Watts

Isolated – Single Output
Standard euro-rack size 19"



Special Features

- Electrostatic discharge: 8kV contact (chassis), 15 kV air, (level 4) according to EN 61000-4-2:2009
- Fast transients (Burst): 2 kV (level 3) / (criterion A) / according to EN 61000-4-4:2004
- Surge: Input immunity 2 kV sym./asym. criterion A according to EN 61000-4-5:2006
- Conducted immunity 10V according to EN 61000-4-6:2007
- Conducted emission:
Input filtering according to EN 55022:2006 class B****
- Zero load operation and short circuit protection
- Overtemperature shutdown
- Remote off (EN) with TTL – L-signal
- Overvoltage protection in the output, even in case of external supply (OVP)
- Reverse polarity protection by internal fuse (diode at $V_{in} = 110V$)
- Extremely low thermal stress of sensitive components due to dissipated power loss over lateral heatsink
- Yellow LED indicate operating mode

Technology

- Power section in 100kHz-MOS-FET-technology
- Regulator section in SMT
- Coated assembly
- Coated and glued parts for better vibration resistance

Specifications

at $\vartheta_{amb}=25^{\circ}C$, $V_{in nom}$, $I_{out nom}$

Temperature	
Ambient air	$\vartheta_{amb} = -40^{\circ}C...+85^{\circ}C$
Storage	$\vartheta_S = -40^{\circ}C...+100^{\circ}C$
Rise inside chassis	$\Delta\vartheta_{Ci} \leq 20 K$
Rise on heat sink	$\Delta\vartheta_K \leq 35 K$
Output voltage	
Tolerance	$\Delta V_{out} \leq \pm 0,5 \%*$
Ripple at $\vartheta_{amb} = -40^{\circ}C...+85^{\circ}C$	$V_{out ripple} \leq 3,5 \%$
Temperature coefficient	$TC \leq 0,016 \% / K$
Regulation at $\vartheta_{amb} = -40^{\circ}C...+85^{\circ}C$	
Line reg. for $V_{in range}$	$\Delta V_{out} \leq 2 mV$
Load reg. static	$\Delta V_{out} \leq 10 mV / A$
Load change (25°C)**	$\Delta V_{out} \leq 55 (45) mV / A$
Output "Power Good"	
Admissible voltage	$V_{CEO} \leq 24 V$
Admissible current	$I_C \leq 20 mA$
Saturation voltage	$V_{CE(sat)} \leq 1,2 V$
OVP	
Starting point /%	$V_{out off} \leq 130 \% V_{out nom}$
Admissible continuous external current	$I_{ext} \leq 6 A$
Isolation – voltage strength	
In-/Output	$V_{iso i/o} \geq 1,5 kVrms$
Input to case	$V_{iso i/c} \geq 1,5 kVrms$
Output to case	$V_{iso o/c} \geq 0,5 kVrms$
Resistance In-/Output	$R_{iso} \geq 1,5 G\Omega$
Capacitance In-/Output	$C_{iso} \leq 7000 (4200) pF$
Degrees of protection (inserted in rack)	= IP20****
Weight	M ca. 695 g

Block Diagram

- 4 = $-V_{out}$
- 6 = $+V_{out}$
- 8 = +S (Sense)
- 10 = -S (Sense)
- 12 = n.c.
- 14 = n.c.
- 16 = n.c.
- 18 = -PG (-Power Good)
- 20 = +PG (+Power Good)
- 22 = TR (Tracking)
- 24 = EN (ON/OFF)
- 26 = GND (TR and EN)
- 28 = $+V_{in}$
- 30 = $-V_{in}$
- 32 = \varnothing / \oplus

Sense connection is not required.

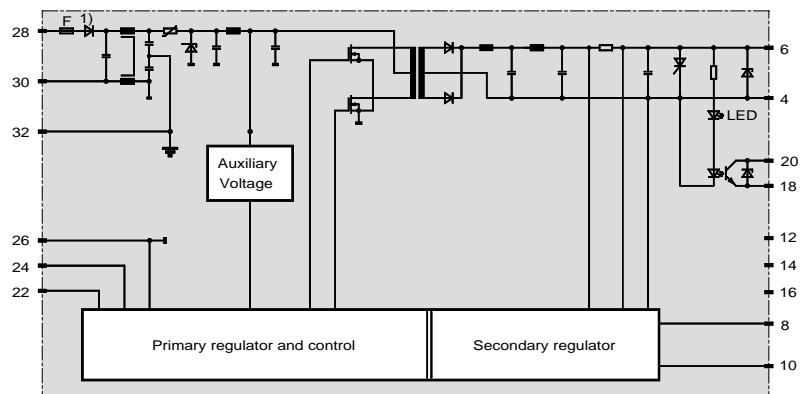

1) only at $V_{in nom} = 110V$

* At 5V: 1%

** $I_{out min} = 0,1 I_{out nom}$

*** Higher degrees of protection by properly mounting

**** In built-in condition our devices may show different EMC properties



Drawing

Dimensions in mm
Tolerance: general $\pm 1\text{mm}$

Front panel DIN ISO 2768-1m

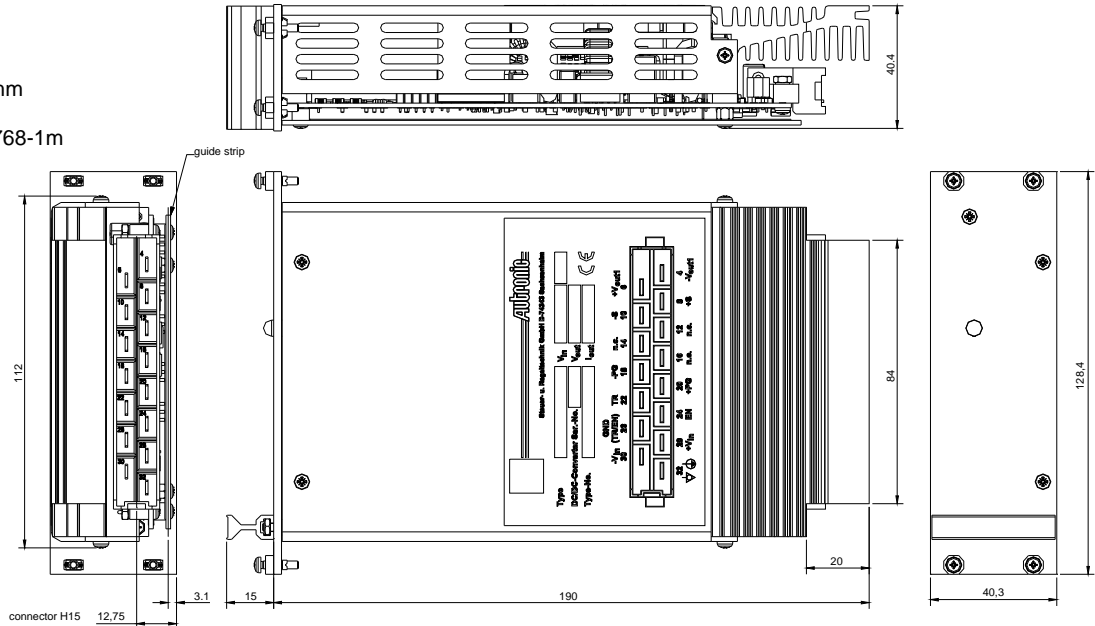

Operating Instructions

Installation: The converters have to be installed according to the guidelines currently in force, like other open electronic component assemblies. Attention must be paid to sufficient ventilation, fastening and protection against accidental contact! Plug in not under voltage if converter connected parallel or in series.

Reverse polarity protection: The converters are equipped with a soldered-in time-lag fuse corresponding to IEC 127-2 for input protection. For rating of fuse refer to listing below. Pay attention on sufficient current of current source in case of short-circuit.

Connector pin 32 (PE) - Equipotentiality/PE: This pin has to be properly connected in order to assure operation.

Excess temperature protection: In case of inside temperatures exceeding $>101^{\circ}\text{C}$, typ. 105°C , (due to inadmissible operation conditions) the output voltage are automatically switched off and restarted after cooling down about 10K.

External shutdown (EN): $V < 0,8\text{ V}$ at pin 24 (EN) to pin 26 or connecting an active transistor with open collector to this pins switches off the output. $I_{\text{source}} 500\ \mu\text{A}$

Overvoltage protection: Externally or internally caused overvoltage at the output leads to a thyristor controlled short-circuit of the output. After elimination of the overvoltage the output voltage restarts automatically latest after 1s.

Output voltage monitoring (Power Good): Simultan to the lighting of a LED a transistor with open-collector switches on. Level V_{PG} see table below.

Current limiting: $I_{\text{out lim}} = 1,1 \dots 1,2 I_{\text{out nom}}$. At more than $1,5 I_{\text{out nom}}$ the output switches off and restarts automatically latest after 1s of elimination of the overload.

Tracking operation: If the pins 22 as well as 26 of two or more converters are connected, the output voltages in case of short-circuit or overload go synchronously down and restart at the same moment.

Sense operation: Sense connection is not required. If it is accomplished, the voltage at the load is reduced by approx. 100 mV. The voltage drop on the interconnection leads between the converter and the load should not exceed 0,5 V.



Standard converters AVP/KE

V _{out} V	I _{out} ²⁾ A	η ³⁾ %	V _{PG} ⁵⁾ VDC	V _{in,nom} VDC	V _{in,Operating} VDC	V _{in,Range} VDC	I _{in,max} A	Internal Fuse A	Order Numbers
5 ¹⁾	7,5	79	> 3,5	12/24 ⁴⁾	9...30	9...40 ⁴⁾	11	16	09 49 61 0102 4
	10	80		24	16,8...30	15...36	8	16	09 49 91 0102 7
	10	81		36	24,2...45	19...51	6	10	09 49 31 0102 1
	10	84		48	33...30	32...74	3,5	6,3	09 49 51 0102 6
	10	85		72	50...90	43,2...101	2,6	3,6	09 49 21 0102 3
	10	85		110	77...138	66...154	1,7	2,5	09 49 71 0102 2
12	6	80	> 9,5	12/24 ⁴⁾	9...30	9...40 ⁴⁾⁶⁾	11	16	09 49 62 0102 3
	8	83		24	16,8...30	15...36	8	16	09 49 92 0102 6
	8	84		36	24,2...45	19...51	6	10	09 49 32 0102 9
	8	86		48	33...30	32...74	3,5	6,3	09 49 52 0102 5
	8	87		72	50...90	43,2...101	2,6	3,6	09 49 22 0102 2
	8	87		110	77...138	66...154	1,7	2,5	09 49 72 0102 1
15	4,9	81	> 13	12/24 ⁴⁾	9...30	9...40 ⁴⁾⁶⁾	11	16	09 49 63 0102 2
	6,5	83		24	16,8...30	15...36	8	16	09 49 93 0102 5
	6,5	85		36	24,2...45	19...51	6	10	09 49 33 0102 8
	6,5	86		48	33...30	32...74	3,5	6,3	09 49 53 0102 4
	6,5	87		72	50...90	43,2...101	2,6	3,6	09 49 23 0102 1
	6,5	87		110	77...138	66...154	1,7	2,5	09 49 73 0102 9
24	3	82	> 21	12/24 ⁴⁾	9...30	9...40 ⁴⁾	11	16	09 49 64 0102 1
	4	84		24	16,8...30	15...36	8	16	09 49 94 0102 4
	4	85		36	24,2...45	19...51	6	10	09 49 34 0102 7
	4	86		48	33...30	32...74	3,5	6,3	09 49 54 0102 3
	4	87		72	50...90	43,2...101	2,6	3,6	09 49 24 0102 9
	4	87		110	77...138	66...154	1,7	2,5	09 49 74 0102 8

Reference numbers for option "EMC fingerstrips" and other options on request

1) Adjusted to 5,1V

2) At -25°C...+70°C

Derating: 70°C and 85°C: 4%/°C

3) Typical at V_{in,nom}

4) Output current 75% of the table values

5) V_{PG} = Switching point for the output level "Power Good"

6) Like 4) + additional derating from 55°C...70°C: 2%/°C

Models in blue are not recommended for new designs.

Models in red are obsolete.