

DC-DC CONVERTER AER20-W / AER20-DW

RAILWAY CONVERTER.

FOR PCB MOUNTING



HIGHLIGHTS

- + Output Power up to 20 Watts
- + Efficiency up to 90 %
- + Ultra Wide Input Range
- + Wide Temperature Range
- + Remote On/Off
- + RoHS compliance
- + According to EN50155

INPUT

Input Voltage Nominal 12, 24, 36, 48, 72, 96 and 110 VDC

OUTPUT

Output Voltage	5, 12, 15, $\pm 12V$, $\pm 15V$ and $\pm 24 V$
Initial Set Accuracy	< 1 %*
Minimum Load	No minimum load
Short Circuit	Continuous short circuit proof
Line Regulation	< 0,2 %
Load Regulation	Single Output $\pm 0,2$ % (0 % - 100 % load) Dual Output $\pm 1,0$ % (0 % - 100 % load)
Ripple & Noise	40 mV RMS, 75mV pk-pk (5V), 100mV pk-pk , 20 MHz bandwidth, (see note 1 page 3)
Start Time	15ms typ (5 V) other 10 ms typ.
Max. Output Capacitance	See table page 2
Temperature Coefficient	< 0.02 %/°C

FEATURES

Remote On/Off	See notes 2 & 3 page 3
Trim	-20 %, +15 % adjustable output voltage (with an external resistor for single Version only)
Inrush Current	0,1A ^{2s}

PROTECTION

Over Temperature Protection (OTP)	Shut down at typ. 110°C baseplate temp. with about 15°C hysteresis and auto recovery
Over Voltage Protection (OVP)	125 % typ $V_{out nom}$
Over Current Protection (OCP)	110-180 % $I_{out nom}$

GENERAL

Product Standard	EN 50155
Isolation	Input to Output 4200 VDC, Reinforced
Isolation Resistance	> 1000M Ω (@ 500 VDC)
Isolation Capacitance	Typ. 20pF (10kHz, 0,25V)
Switching Frequency	Typ. 200 KHz
Lead Temperature	260°C (1,5 mm from case for 10 sec.)
Dimensions [mm]	50.8 x 25.4 x 10.2
Weight	28.5 g
MTBF	1570.000h acc. to MIL-HDBK-217F (GB, 25°)
Fire & Smoke	EN 45545-2

ENVIRONMENTAL

Operating Ambient Temp.	-40°C to - 85°C**
Operating Case Temp.	-40°C to +105°C
Max. Operating Altitude	5000 m
Storage Temperature	-55°C to +125°C
Vibration / Shock / Bump	EN 61373:1999 Cat. 1B

EMC

EMC Standard	EN 50121-3-2:2016, see note 4 page 3
Conducted Emissions	EN 55011, Class A, with external input filter***
ESD Immunity	EN 61000-4-2:2009 Air ± 8 kV, Contact ± 6 kV, Criteria A
Burst	EN 61000-4-4:2012 ± 2 kV, Criteria A****
Surge	EN 61000-4-5:2014 line to line ± 1 kV, 42R, Crit.A****
Conducted Immunity	EN 61000-4-6:2014 10 V, Criteria A
Radiated Immunity	EN 61000-4-3:2006 20 V/m, Criteria A
Safety	UL60950-1 2 nd (reinforced insulation)

* For $T_{amb} = 25^{\circ}C$, $V_{in nom}$, $I_{out nom}$

** See page 5

*** In built-in condition our devices may show different EMC properties

**** With external capacitor and suppressor diode

TECHNICAL DATA

For $T_{amb}=25^{\circ}C, V_{in nom}, I_{out nom}$, unless otherwise specified

SPECIFICATION Input 14 - 160 VDC**

	TYPE	AER20-W			AER20-W			AER20-W			
	ORDER NUMBER	11 75 12 2051 1			11 75 12 2121 3			11 75 12 2151 3			
	CHARACTERISTIC	Unit	Min	Typ	Max	Min	Typ	Max	Min	Typ	Max
INPUT	Input Voltage Operating**	V	8,5...160								
	Max. Input Surge Voltage (100 ms max.)	V	200								
	Under Voltage Turn-on	V	9			9			9		
	Under Voltage Turn-off	V	7,5			7,5			7,5		
	Input Current @ Full Load 72 V	mA	323			312			312		
	Input Current @ No Load (typ.)	mA	5			8			8		
	Standby Input Current (typ.)	mA	3								
OUTPUT	Output Voltage	V	5			12			15		
	Output Current	mA	4000			1670			1330		
	Output Power	W	20			20			20		
	Max. Capacitive Load	μ F	6800			3300			2200		
	Efficiency @ Full Load 72V	%	86			89			89		
	Efficiency @ Full Load 110V	%	85			88			88		
	Output Current Limit Inception*	%									
	Transient Response 75% / 100% Load Step, Recovery Time <250 μ s	%	± 5								

* Hiccup mode, auto recovery

SPECIFICATION Input 14 - 160 VDC - Negative Remote On/Off logic**

	TYPE	AER20-DW			AER20-DW			AER20-DW			
	ORDER NUMBER	11 75 12 2122 7			11 75 12 2152 7			11 75 12 2242 6			
	CHARACTERISTIC	Unit	Min	Typ	Max	Min	Typ	Max	Min	Typ	Max
INPUT	Input Voltage Operating**	V	8,5...160								
	Max. Input Surge Voltage (100 ms max.)	V	200								
	Under Voltage Turn-on	V	9			9			9		
	Under Voltage Turn-off	V	7,5			7,5			7,5		
	Input Current @ Full Load 72 V	mA	312			312			309		
	Input Current @ No Load (typ.)	mA	8			8			8		
	Standby Input Current (typ.)	mA	3								
OUTPUT	Output Voltage	V	± 12			± 15			± 24		
	Output Current	mA	± 833			± 667			± 417		
	Output Power	W	20			20			20		
	Max. Capacitive Load	μ F	820			680			330		
	Efficiency @ Full Load 72V	%	89			89			90		
	Efficiency @ Full Load 110V	%	88			88			89		
	Output Current Limit Inception*	%									
	Transient Response 75% / 100% Load Step, Recovery Time <250 μ s	%	± 5								

* Hiccup mode, auto recovery

** Derating curve see page

TECHNICAL DATA

For $T_{amb}=25^{\circ}\text{C}$, $V_{in\ nom}$, $I_{out\ nom}$, unless otherwise specified

MECHANICAL DETAILS

All Dimensions In Inches (mm)

Tolerances Inches: X.XX= ± 0.02 , X.XXX= ± 0.010

Milimeters: X.X= ± 1.0 , X.XX= ± 0.25

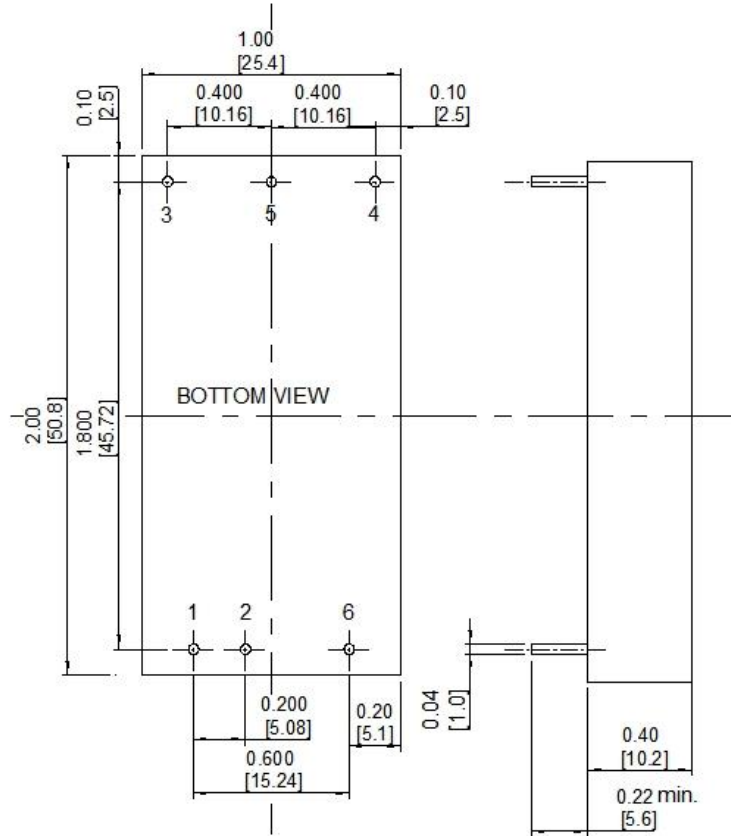

Case Material: Plastic, DAP
 Base Material: FR4 (Hammability to UL 94V-0 rated).
 Potting Material: UL 94V-0
 Pin Material: Base: Copper Plating; Nickel with Matte Tin

PINNING

V	Functional Single	Functional Dual
1	+V _{in}	+V _{in}
2	-V _{in}	-V _{in}
3	+V _{out}	+V _{out}
4	Trim	-V _{out}
5	-V _{out}	Common
6	Remote On/Off	Remote On/Off

NOTES

- Output ripple and noise measured with 1 μ F ceramic capacitor across output.
- Logic compatibility
 Module on: open collector ref to -Input >4.0 VDC to 160 VDC or open circuit
 Module off: 0 to <1.2 VDC
- For model number with negative logic remote on/off
 Module on: 0 to <1.2 VDC
 Module off: >4.0 VDC to 160 VDC or open circuit
- For information about EN 50155 and RIA12, refer to application note.

TECHNICAL DATA

For $T_{amb}=25^{\circ}\text{C}$, $V_{in\ nom}$, $I_{out\ nom}$, unless otherwise specified

BLOCK DIAGRAM

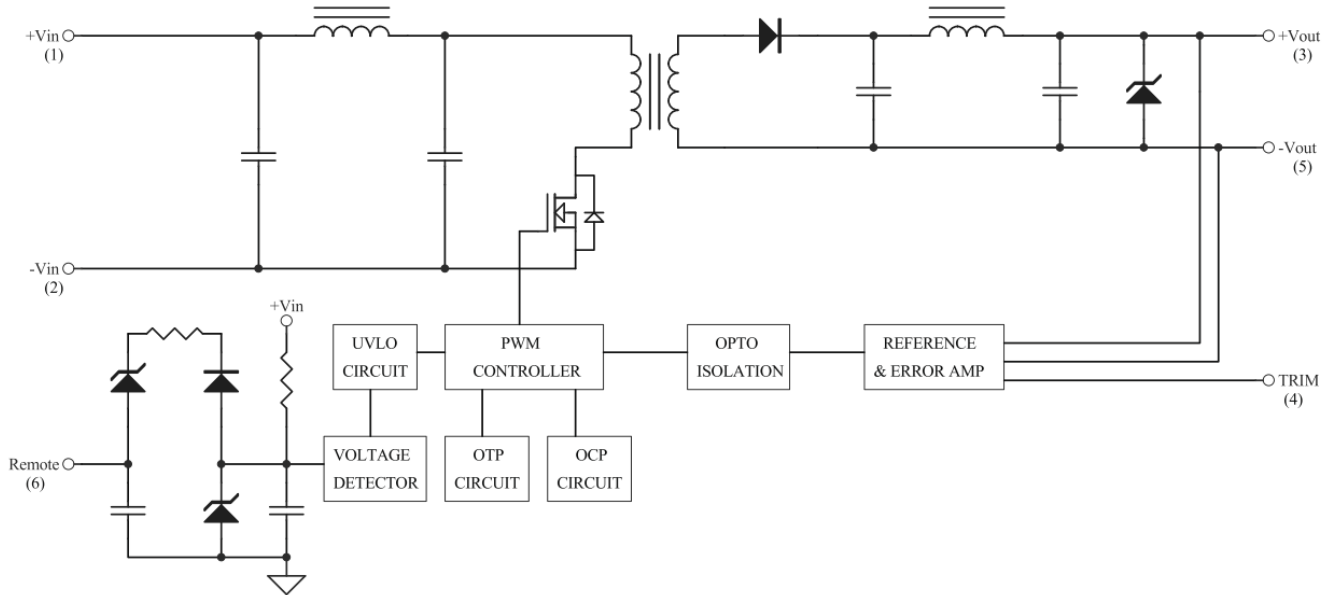

Figure 1. Electrical Block Diagram for Single Output Modules

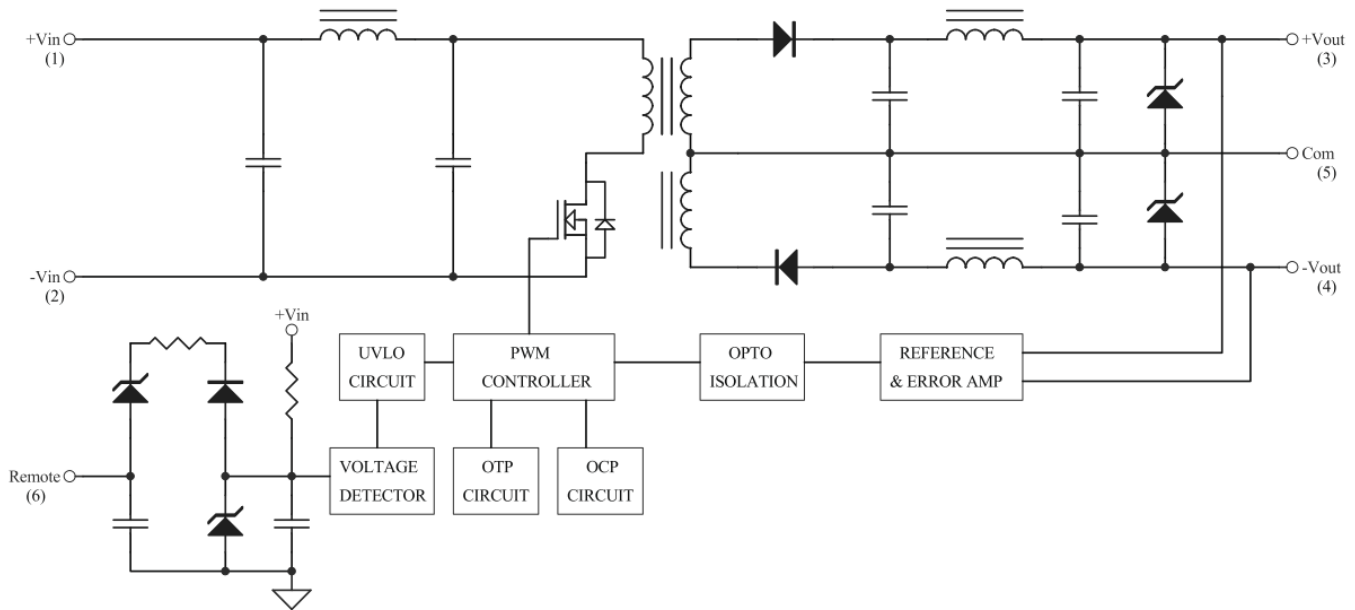

Figure 2. Electrical Block Diagram for Dual Output Module

TECHNICAL DATA

For $T_{amb}=25^{\circ}\text{C}$, $V_{in\ nom}$, $I_{out\ nom}$, unless otherwise specified

POWER DERATING

The operating case temperature range of AER20-W series is -40°C to $+105^{\circ}\text{C}$. When operating the AER20-W series, proper derating or cooling is needed. The maximum case temperature under any operating condition should not exceed 105°C .

The following curve is the de-rating curve of AER20-W series without heat sink.

Typical Derating curve for Natural Convection

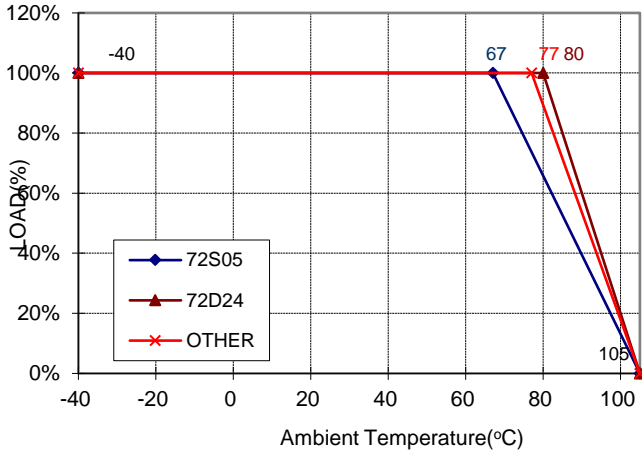

The following curve is the de-rating curve of AER20-W series with heat sink BC100 (K-C088)

Typical Derating curve for Natural Convection

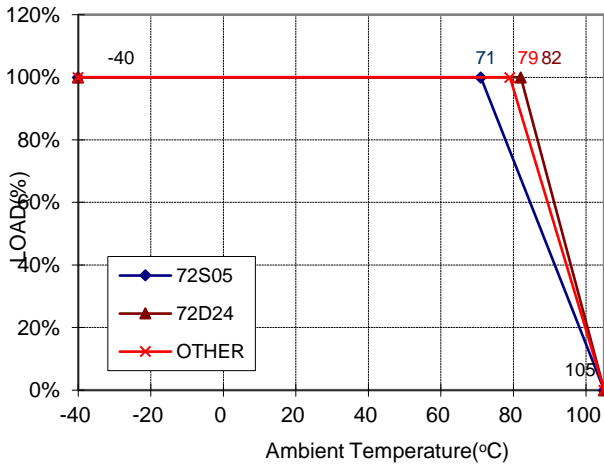

INPUT DERATING CURVE

The AER20-W series has Derating by Input Voltage is required shown below.

Input Voltage Derating Curve

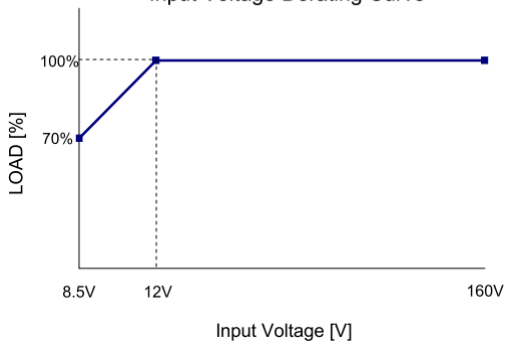

APPLICATION NOTES

INPUT FUSING AND SAFETY CONSIDERATIONS

The AER20-W series converters have no internal fuse. In order to achieve maximum safety and system protection, always use an input line fuse. We recommended a 4A fast acting fuse for all models. It is recommended that the circuit have a transient voltage suppressor diode (TVS) across the input terminal to protect the unit against surge or spike voltage and input reverse voltage (as shown).

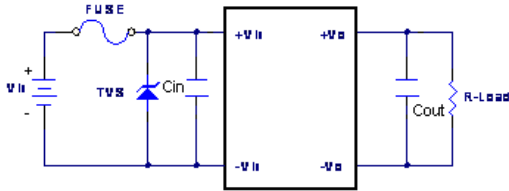

The external TVS is required if AER20-W series has to meet EN 61000-4-4, EN61000-4-5. & EN61000-4-5
The AER20-W series recommended a TVS (Littelfuse 1.5KE180A) & aluminum capacitor (82uF/200V) to connect parallel.

REMOTE ON/OFF

The AER20-W series allows the user to switch the module on and off electronically with the remote on/off feature. All models are available in "positive logic" and "negative logic" (optional) versions. The converter turns on if the remote on/off pin is high (>4.0Vdc to 160Vdc or open circuit). Setting the pin low (0 to <1.2Vdc) will turn the converter off. The signal level of the remote on/off input is defined with respect to ground. If not using the remote on/off pin, leave the pin open (converter will be on). Models with part number suffix "N" are the "negative logic" remote on/off version. The unit turns off if the remote on/off pin is high (>4.0Vdc to 160Vdc or open circuit). The converter turns on if the on/off pin input is low (0 to <1.2Vdc). Note that the converter is off by default.

Logic State (Pin 6)	Negative Logic	Positive Logic
Logic Low – Switch Closed	Module on	Module off
Logic High – Switch Open	Module off	Module on

The converter remote On/Off circuit built-in on input side. The ground pin of input side Remote On/Off circuit is -Vin pin. Connection examples see below.

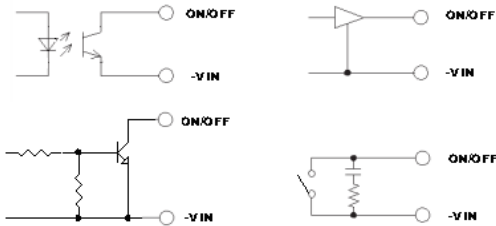

OUTPUT TRIMMING

Output may be externally trimmed -20% to +15% (Single output models only) with a fixed resistor or an external trim pot as shown (optional). Model specific formulas for calculating trim resistors are available upon request as a separate document.

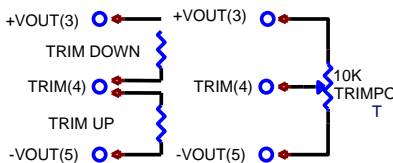

In order to trim the voltage up or down, one needs to connect the trim resistor either between the trim pin and -Vout for trim-up or between trim pin and +Vout for trim-down. The output voltage trim range is -20% to +15%. This is shown:

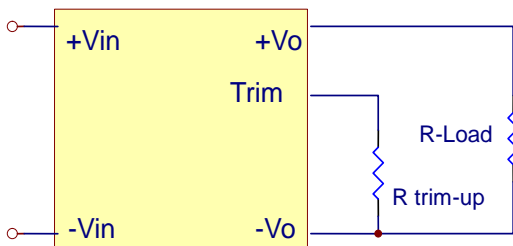

Trim-up Voltage Setup

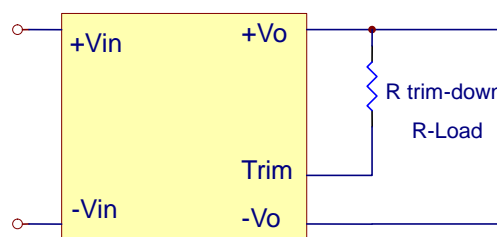

Trim-down Voltage Setup

APPLICATION NOTES

EMC CONSIDERATIONS

EMI Test standard: EN 55032 Conducted & Radiated Emission, EN50121-3-2:2016 Output Conducted Emission
 Test Condition: Input Voltage: 110Vdc, Output Load: Full Load

(1) EMI meet EN 55011 / EN 55032 / EN 50121-3-2:2016

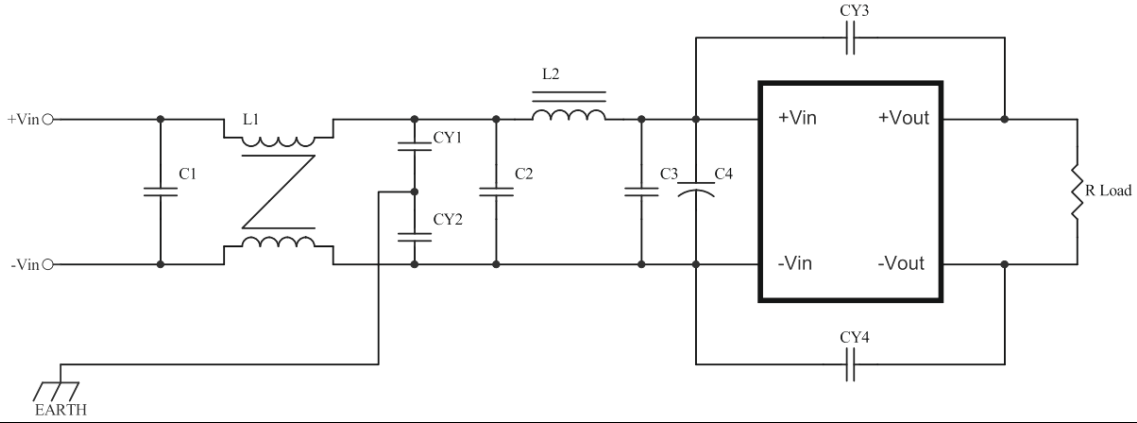

C1, C2, C3	C4	CY1, CY2	CY3, CY4	L1	L2
1uF/250V 1812 Ceramic Cap.	120uF/220V KXJ Series Aluminum Cap.	1500pF/400V Y1 Cap	2200pF/400V Y1 Cap	VAKOS R10K T10x6x5C 1.4mH ø0.4mmx1/12T	10uH/7A 2525CZ Vishay

CHANGE HISTORY

Revision	Date	Author	Modification
A00	11.02.2020	Ehrhardt	First Revision