

DC/DC Converter EC 02 Series

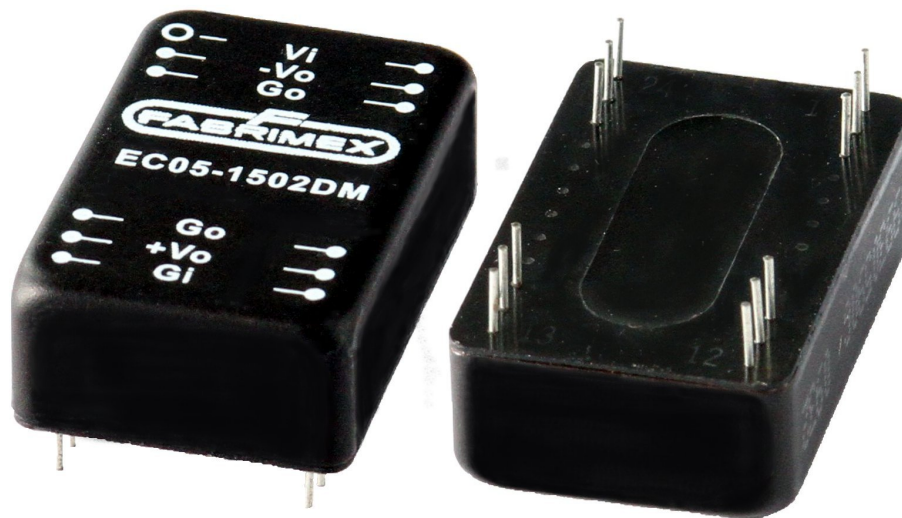

- * I/O isolation of 500V/1.5kV/3kVdc
- * Pi-filter at input
- * Short circuit protection
- * Linear regulation
- * No derating up to 71°C
- * Low output ripple and noise
- * Low silhouette
- * Six sides shielded or non conductive plastic case

Product Range

Model	Input		I _{in} @ U _{in} nom.		U _{out}	Output		Efficiency typ.	Max. capacity
	nominal	range	full load	no load		U _{out}	power		
Single									
EC05-0502SM	5 Vdc	±10%	620 mA	110 mA	5.0 Vdc	300 mA	1.5 W	50%	
EC05-1202SM	5 Vdc	±10%	550 mA	110 mA	12.0 Vdc	125 mA	1.5 W	50%	
EC05-1502SM	5 Vdc	±10%	550 mA	110 mA	15.0 Vdc	100 mA	1.5 W	50%	
EC12-0502SM	12 Vdc	±10%	260 mA	40 mA	5.0 Vdc	300 mA	1.5 W	50%	
EC12-1202SM	12 Vdc	±10%	215 mA	40 mA	12.0 Vdc	125 mA	1.5 W	50%	

EC12-1502SM	12 Vdc	±10%	215 mA	40 mA	15.0 Vdc	100 mA	1.5 W	50%
EC24-0502SM	24 Vdc	±10%	130 mA	20 mA	5.0 Vdc	300 mA	1.5 W	50%
EC24-1202SM	24 Vdc	±10%	115 mA	20 mA	12.0 Vdc	125 mA	1.5 W	50%
EC24-1502SM	24 Vdc	±10%	115 mA	20 mA	15.0 Vdc	100 mA	1.5 W	50%
EC48-0502SM	48 Vdc	±10%	65 mA	15 mA	5.0 Vdc	300 mA	1.5 W	50%
EC48-1202SM	48 Vdc	±10%	60 mA	15 mA	12.0 Vdc	125 mA	1.5 W	50%
EC48-1502SM	48 Vdc	±10%	60 mA	15 mA	15.0 Vdc	100 mA	1.5 W	50%
Dual								
EC05-1202DM	5 Vdc	±10%	550 mA	110 mA	+12.0 Vdc -12.0 Vdc	+60 mA -60 mA	0.72 W 0.72 W	50%
EC05-1502DM	5 Vdc	±10%	550 mA	110 mA	+15.0 Vdc -15.0 Vdc	+50 mA -50 mA	0.75 W 0.75 W	50%
EC12-1202DM	12 Vdc	±10%	215 mA	40 mA	+12.0 Vdc -12.0 Vdc	+60 mA -60 mA	0.72 W 0.72 W	50%
EC12-1502DM	12 Vdc	±10%	215 mA	40 mA	+15.0 Vdc -15VDC	+50 mA -50mA	0.75 W 0.75W	50%
EC24-1202DM	24VDC	21.6...26.4VDC	115mA	20mA	+12VDC -12VDC	+60mA -60mA	0.72W 0.72W	50%
EC24-1502DM	24VDC	21.6...26.4VDC	115mA	20mA	+15VDC -15VDC	+50mA -50mA	0.75W 0.75W	50%
EC48-1202DM	48VDC	43.2...52.8VDC	60mA	15mA	+12VDC -12VDC	+60mA -60mA	0.72W 0.72W	50%
EC48-1502DM	48VDC	43.2...52.8VDC	60mA	15mA	+15VDC -15VDC	+50mA -50mA	0.75W 0.75W	50%

Nomenclature

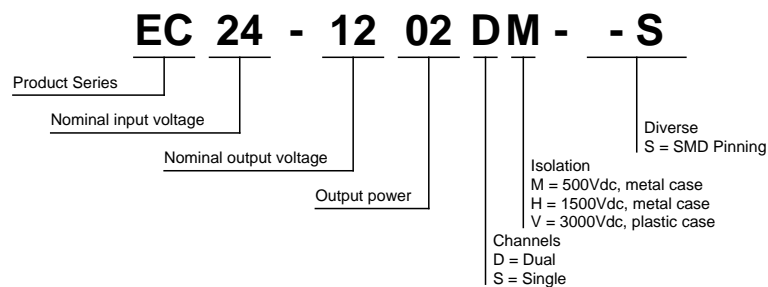

Specifications

All values refer to an ambient temperature of 25°C and nominal rated values where nothing else is specified.

Input Specifications

Characteristic	Conditions	min	typ	max	unit
U_{IN} Input voltage	$T_A < T_{MAX}$	See	product	range	V
U_{UVLO} Under voltage lockout					V
Max. input current at full load	$I_0 = I_{0max}$	See	product	range	A
No load input current	$I_0 = 0$	See	product	range	mA

Output Specifications

Characteristic		Conditions	min	typ	max	unit
U _{ACC}	Output voltage accuracy			±4		%
	Output voltage adjust			±4		%
	Line regulation				±0.3	%
	Load regulation			±0.5		%
	Load transient recovery time					us
	Load transient error band					%
	Temperature coefficient			±0.02		%/K
	Ramp up time					ms
	Start up time					ms
	Ripple and noise	BW = 20MHz	5V: 50, 12&15V: 70			mVpp
	Current limit					% Inom
	Over voltage protection					% Unom
	Short circuit protection					% Inom
	Short circuit characteristic		Momentary			

General Specifications

Characteristic		Conditions	min	typ	max	unit
U _{ISO}	Isolation voltage		500, 1500 or 3000			Vdc
R _{ISO}	Isolation resistance		1G			Ohm
F _{SW}	Switching frequency	Fixed	20			kHz
	Approvals					
	Safety Approvals					
	MTBF					h
	Case material		Copper, black coated			
	Compound material					
	PCB material					
	Weight		15			gr
	Dimensions		31.8 x 20.3 x 10.2			mm
	Soldering infos		275°C for 10			s

EMC Specifications

Characteristic		Conditions				
	EMC conducted	See EMC information	EN55022 Curve B			

Environmental Specifications

Characteristic		Conditions	min	typ	max	unit
T _{AMB}	Operation temperature	See derating diagram	-40...+95/100°C (Tcase)			°C
T _{AMB}	Storage temperature		-40...+100			°C
T _{SD}	Thermal shutdown range		None			°C

EMC information

EMC emissions conducted, EN55022 Curve B, Example: EC12-0502SM

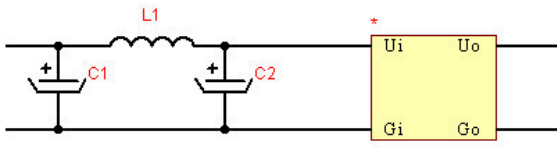
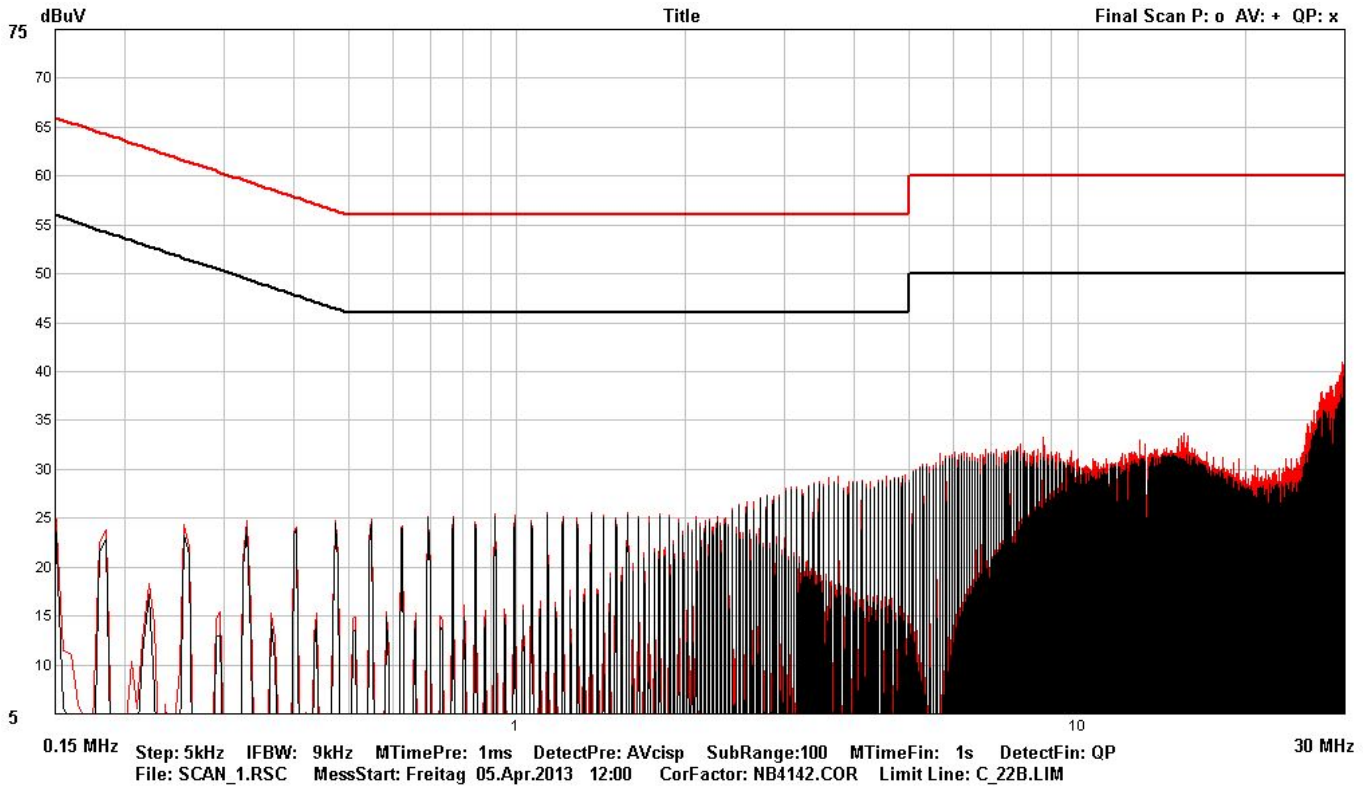

This was achieved with the following filter:
 C1 10uF/50V B45197
 C2 10uF/50V B45197
 L1 10uH / 1.2A Coilcraft DS1608C-103

Block diagram

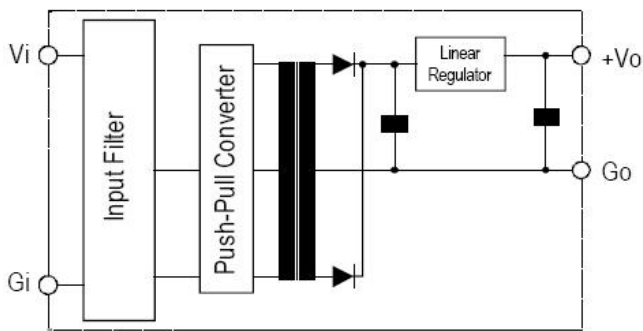

Single output converter block diagram

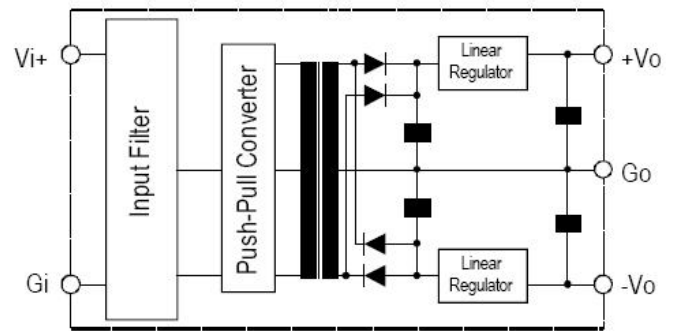

Dual output converter block diagram

Derating

The operating case temperature range of EC 02 series is $-40...+95/100^{\circ}\text{C}$ (T_{case}). When operating the EC 02 series, proper derating or cooling is needed. The following curves are the derating curves of EC 02. Please note that these are relative values in a test environment. Ambient temperature can not be exactly defined in an application, only the case temperature.

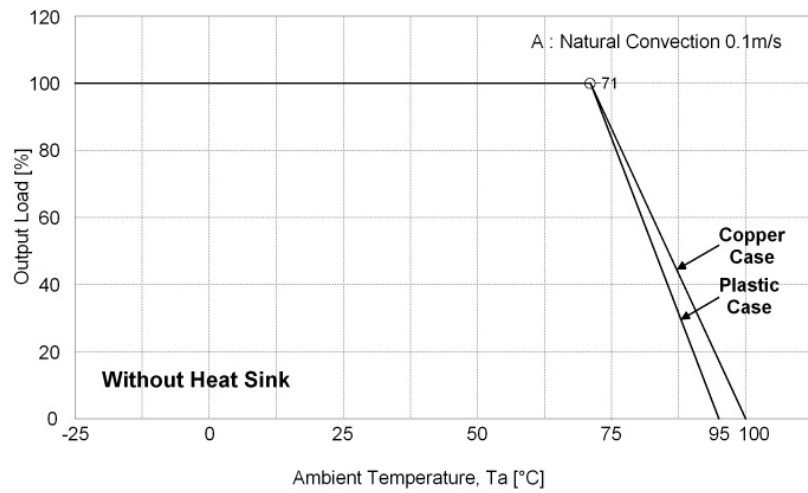

Own notes

Case

Normal tolerance 1/10 ±0.5 mm, 1/100 ±0.25 mm; Pin tolerance ±0.05 mm diameter

NP = No pin, NC = Not connected, NA = Not available for electrical contact, do not connect, (opt) = optional

500V THD & SMD

BOTTOM VIEW SIDE VIEW

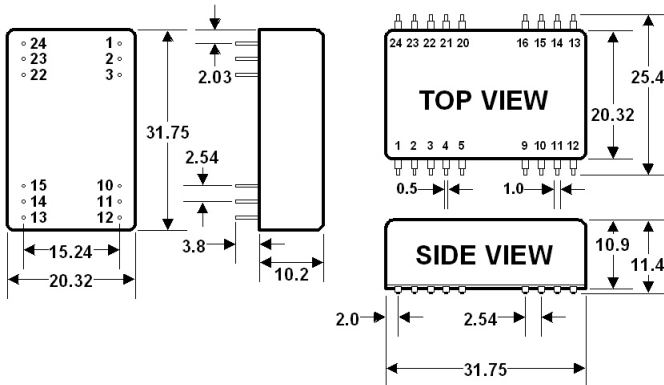

Pin	Single	Dual	Pin
1	+Vi	+Vi	1
2	NC	-Vo	2
3	NC	Go	3
10	Go	Go	10
11	+Vo	+Vo	11
12	Gi	Gi	12
13	Gi	Gi	13
14	+Vo	+Vo	14
15	Go	Go	15
22	NC	Go	22
23	NC	-Vo	23
24	+Vi	+Vi	24

3000V THD & SMD

BOTTOM VIEW SIDE VIEW

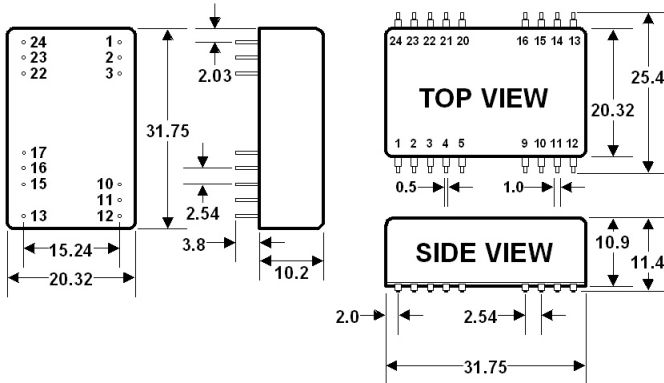

Pin	Single	Dual	Pin
1	Vi	Vi	1
2	Vi	Vi	2
3	Vi	Vi	3
10	NP	Go	10
11	NP	Go	11
12	Go	-TP	12
13	+Vo	-Vo	13
15	NP	+Vo	15
16	NP	+TP	16
17	+TP	NP	17
22	Gi	Gi	22
23	Gi	Gi	23
24	Gi	Gi	24

Cleaning

The modules are cleanable with the today's known and in the electronics industry usually used products. Due to the different cleaning processes and new available products, we highly recommend to do a compatibility test when using the converters the first time.

Notice: All statements, technical information, and recommendations related to FABRIMEX's products are based on information believed to be reliable, but the accuracy or completeness thereof is not guaranteed. Before utilizing the product, the user should determine the suitability of the product for its intended use.

Switzerland:
FABRIMEX AG - Techcenterstr. 2
CH-8608 Bubikon
Tel: +41 55 253 31 90 - Fax: +41 55 253 31 91
www.fabrimex.com
info@fabrimex.ch



FABRIMEX
POWER SUPPLIES

Germany:
CAC FABRIMEX GmbH - Karlstrasse 70
D-89543 Gerstetten
Tel: +49 7323 95000 - Fax: +49 7323 95050
www.fabrimex.de
info@cac-fabrimex-ger.de