

DC-DC CONVERTER HFBC60-xxW/O

RAILWAY CONVERTER.

FOR CHASSIS MOUNTING



HIGHLIGHTS

- + Output Power up to 60 Watts
- + Ultra Wide Input Range
- + Wide Temperature Range
- + Hold-up-time > 10ms
- + RoHS compliance
- + According to EN50155

INPUT

Input Voltage Nominal	24, 36, 48, 72 and 110 VDC
Input Voltage Operating	16,8-138 VDC
Input Voltage Range	14,4-154 VDC (t ≤ 1,0 sec.)
No Load Input Current	See table page 2
Internal Fusing	5 AT

OUTPUT

Output Voltage	5,1 V / 12 V and 24 V
Initial Set Accuracy	< 0,5 % (no load)
Minimum Load	No minimum load
Short circuit	Continuous short circuit proof
Line Regulation	< 1 %
Load Regulation	< 1,6 % (0% - 100% load)***
Ripple & Noise	< 1 % pk-pk, 20 MHz bandwidth
Start Time	< 250 ms
Max. Output Capacitance	500 uF x I _{out nom}
Temperature Coefficient	< 0.016 %/°C

FEATURES

Enable Signal	EN connected to V _{in} + : ON; EN open or connected to V _{in} - : OFF.
Active Reverse Polarity Protection	Max. 160 V
Inrush Current Limitation	Max. 6,5 A
Hold-up-time	> 10 ms at T _{amb} > - 25°C at full load
Power Good Signal	Open-collector Output

PROTECTION

Output Over Voltage Protection (OVP)	110-130 % V _{out nom} (latched, reset through EN or power off)
Over Current Protection (OCP)	See table page 2
Over Temperature Protection (OTP)	Shutdown at +100°C-105°C baseplate temp. with about 5°C hysteresis and auto recovery.

GENERAL

Product Standard	EN 50155:2007
Isolation	2200 VDC Input to Output 2200 VDC Input to Earth (PE) 710 VDC Output to Earth (PE)
Switching Frequency	Typ. 130 kHz
Dimensions [mm]	146 x 100 x 32
Weight	approx. 350 g
MTBF	TBD

ENVIRONMENTAL

Operating Ambient Temp.	-40°C to +70°C*
Storage Temperature	-40°C to +100°C
Vibration / Shock	EN 61373:1999, Cat. 1B

EMC

EMC Standard	EN 50121-3-2:2006
Conducted Emissions	EN 55011:2007+A2:2007, Class B, QP**
ESD Immunity	EN 61000-4-2 :2009, level 3 (6kV/8kV), Criteria A
Burst	EN 61000-4-4:2004, level 3 (2kV), Criteria A
Surge	EN 50121-3-2:2006, line to line ±1kV, 42R, and line to case ±2kV, 42R, Criteria B
Conducted Immunity	EN 61000-4-6:2007+A1:2001, level 3 (10V), Criteria A

* +70°C continuously, +85°C max. 10 minutes at full load (baseplate temp. must not exceed +100°C)

** In built-in condition the devices may show different EMC properties.

*** Value could be higher, depending on the voltage drop of the connector.



TECHNICAL DATA

For $T_{amb} = 25^{\circ}\text{C}$, $V_{in\ nom}$, $I_{out\ nom}$, unless otherwise specified

SPECIFICATION Input 14,4 - 154 VDC

TYPE		HFBC60-2DW/O					
ORDER NUMBER		87 65 65 0112 4					
CHARACTERISTIC		Unit					
INPUT	Input Voltage Nominal	V	24	36	48	72	110
	Input Voltage Range	V	14,4...36	21,6...51	28,8...67,2	43,2...101	66...154
	Under Voltage Turn-on	V	<16,8				
	Under Voltage Turn-off	V	<14,4 (14,4V < Vin < 16,8V at t > 1 sec.)				
	Input Current @ Full Load	A	2,78	1,83	1,36	0,90	0,58
	Input Current @ No Load*	A	0,18	0,12	0,09	0,06	0,04
	Input Current disabled mode	mA	5,4	4,7	3,8	3,6	3,8
	OUTPUT			Output 1		Output 2	
Output Voltage Nominal		V	12		5*		
Output Current Nominal		A	2		6		
Output Power		W	54				
Efficiency @ Full Load (typical)		%	81	82	83	84	85
Output Current limit		A	2,2...2,6		6,6...7,8		
Short Circuit Current (typical)			2,2		6,6		
Transient Response 25 % / 75 % Load Step Recovery Time < 1 ms		mV	±64		±70		

SPECIFICATION Input 14,4 - 154 VDC

TYPE		HFBC60-W/O					
ORDER NUMBER		87 64 24 0112 8					
CHARACTERISTIC		Unit					
INPUT	Input Voltage Nominal	V	24	36	48	72	110
	Input Voltage Range	V	14,4...36	21,6...51	28,8...67,2	43,2...101	66...154
	Under Voltage Turn-on	V	<16,8				
	Under Voltage Turn-off	V	<14,4 (14,4V < Vin < 16,8V at t > 1 sec.)				
	Input Current @ Full Load	A	TBD	TBD	TBD	TBD	TBD
	Input Current @ No Load*	A	TBD	TBD	TBD	TBD	TBD
	Input Current disabled mode	mA					
	OUTPUT			Output 1			
Output Voltage Nominal		V	24				
Output Current Nominal		A	2,5				
Output Power		W	60				
Efficiency @ Full Load (typical)		%	82	83	85	85	86
Output Current limit		A	3,2...4				
Short Circuit Current (typical)		A	TBD				
Transient Response 25 % / 75 % Load Step Recovery Time < 1 ms		mV	TBD				

* Output 2 adjusted to 5,1 V



TECHNICAL DATA

For $T_{amb} = 25^{\circ}\text{C}$, $V_{in\ nom}$, $I_{out\ nom}$, unless otherwise specified

MECHANICAL DETAILS

- Dimensions in mm
- Unless otherwise specified, general tolerances $\pm 0,5$ are for values in brackets (XX)
Values not in brackets are according to ISO-2768-m

Coating: Lackwerke Peters ELPEGUARD SL 1307-FLZ/342

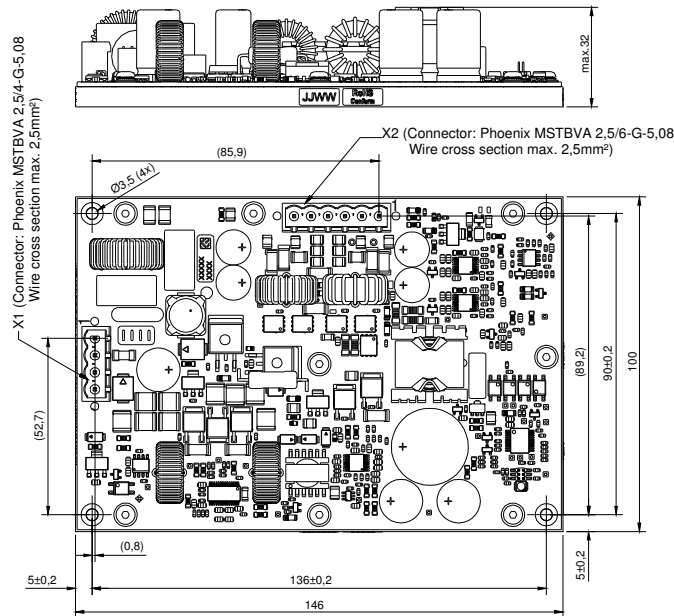

PINNING

Pin	Function	Pin	Function
X1-1	V_{in-}	X2-1	Power Good
X1-2	V_{in+}	X2-2	Internal Connected
X1-3	Enable (EN)	X2-3	V_{out2+}
X1-4	Case (PE)	X2-4	GND (0V)
		X2-5	V_{out1+}
		X2-6	GND (0V)

NOTES

Installation instructions:

The converters have to be installed according to the guidelines currently in force, like other open electronic component assemblies. Attention must be paid to sufficient ventilation, carry off heat, fastening and protection against accidental contact. The mounting surface must be flat and able to remove the thermal energy of the baseplate (baseplate temperature must not exceed +100°C). The pin X1-X4, Case (PE) have to be properly connected in order to assure operation. In built-in condition our devices may show different EMC properties.

Fault protection:

The converters are equipped with a soldered-in-time-lag fuse corresponding to IEC 60127-2 for input protection. In case of fault the supplying current source must be capable to blow the fuse.

BLOCK DIAGRAM

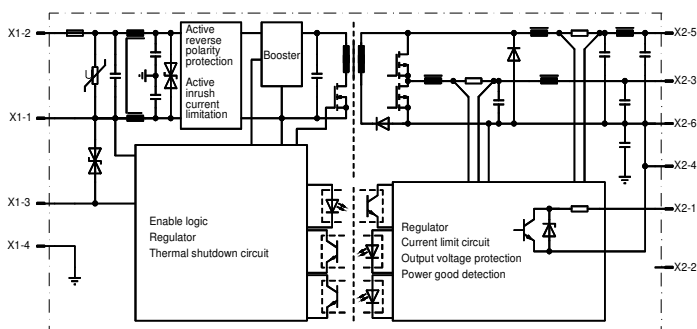



DESCRIPTION OF FEATURES

For $T_{amb} = 25^{\circ}\text{C}$, $V_{in\ nom}$, $I_{out\ nom}$, unless otherwise specified

ENABLE SIGNAL

If the Enable Signal is activated, the converter starts operating.

Enable (X1-3) is activated by a voltage between 10 VDC and 160 VDC referenced to V_{in-} (X1-1).

Typically it is directly switched to V_{in+} to enable the converter. The pin sinks about 1,7 mA.

POWER GOOD SIGNAL

The Power Good (low active) is an open-collector output to inform the system if the output voltages are over 95 % of $V_{out\ nom}$.

Admissible current 5 mA, admissible voltage +24 V, saturation voltage < 1,2 V.

OVER CURRENT PROTECTION

Dual Output:

Output 1 (+12 V): At overload and current limit, the voltage decreases down 0 V. The short circuit current is about 2,2 A.

Output 2 (+5 V): At overload and current limit, the voltage decreases down 0 V. The short circuit current is about 6,6 A.

Single Output:

Output 1 (+24 V): At overload and current limit, the voltage decreases down to about 6 V, then the converter switches-off and tries to restart after 100 ms.

APPLICATION NOTES

For $T_{amb} = 25^{\circ}\text{C}$, $V_{in\ nom}$, $I_{out\ nom}$, unless otherwise specified

DERATING

T_{amb} = Ambient Temperature
 P_{nom} = Nominal Output Power

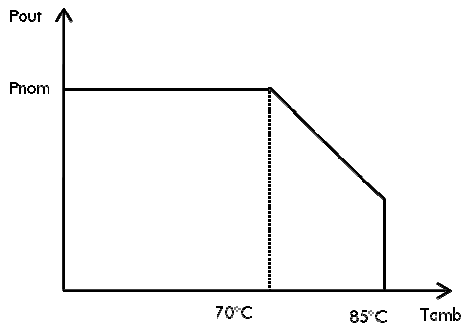

Formula to calculate the P_{nom} derating above 70°C

Single: $P_{out} = 60\text{ W} - 1,93\text{ W/K} \cdot (T_{amb} - 70^{\circ}\text{C})$

Dual: $P_{out} = 54\text{ W} - 1,66\text{ W/K} \cdot (T_{amb} - 70^{\circ}\text{C})$

The calculation is based on a heatsink with $R_{th} = 2,2\text{ K/W}$ (thermal resistance between converter and ambient at free convection in vertical position)