

# GSM7 Medical

## 7 Watt Single Output Global Performance Switchers



### SPECIFICATIONS:

#### Ac Input

85-264 Vac, 47-63 Hz single phase.

#### Holdup Time

20 ms minimum from loss of ac.

#### Output Power

Normal continuous output power is 7 W, 9 W peak for 60 s maximum duration, 10% duty cycle. Factory set to begin power limiting at approximately 9 W.

#### Output Regulation

Regulation from initial setpoint measured by changing load from no-load to 50% load or 50% load to full load in either direction. Initial setpoint tolerance is measured at 50% load. No minimum load is required to maintain proper regulation.

#### Overload Protection

Fully protected against short circuit and output overload. Short circuit protection is cycling type power limit.

#### No Load Turn-on/Standby

Full regulation at no load.

#### Output Noise

0.5% rms, 1% pk-pk, 20 MHz bandwidth, differential mode. Measured with scope probe directly across output terminals of the power supply with load terminated with 0.1 uF capacitor.

#### Voltage Adjustment

Factory set with fixed resistors to maximize reliability.

#### Efficiency

72% minimum for the 5.0 V model at full rated load, nominal input voltage. Efficiency increases as output voltage increases.

#### Input Protection

Internal ac fuse provided on all units. Designed to open only if catastrophic failure occurs in the unit; fuse does not blow on overload or short circuit. Internal 320 Vac MOV included. Units will not be damaged when tested for input transients in accordance with the following standards:

ESD—IEC1000-4-2 Level III  
Fast Transient—IEC1000-4-4 Level III

**NOT RECOMMENDED FOR NEW DESIGNS**  
**GSM7 SERIES TO BE DISCONTINUED IN 2006**  
**SEE GSM11 SERIES FOR DROP IN REPLACEMENT**

### FEATURES:

- World's smallest medically approved 7 W supply
- 2.00" x 2.28" x 0.56"
- Wide-range ac input (85-264 Vac)
- Medical Approval to UL2601-1 and EN60601-1
- EMI conducted to CISPR11 Class B
- Ideal for ultra-compact applications
- **CE** marked to LVD

#### Environmental

Designed for 0 to 50°C operation at full rated output power; derate output current and total output power by 2.5% per °C above 50°C. See Environmental specification on next page.

#### Medical EMI/EMC Compliance

All models include built-in EMI filtering to meet the following emissions requirements:

| EMI SPECIFICATIONS      | COMPLIANCE LEVEL                    |
|-------------------------|-------------------------------------|
| Conducted Emissions     | EN55011 Class B; FCC Class B        |
| Static Discharge        | EN61000-4-2, 6 kV contact, 8 kV air |
| RF Field Susceptibility | EN61000-4-3, 3 V/meter              |
| Fast Transients/Bursts  | EN61000-4-4, 2 kV, 5 kHz            |
| Surge Susceptibility    | EN61000-4-5, 1 kV diff., 2 kV com.  |

#### Medical Safety

Condor D.C. Power Supplies, Inc. declares under our sole responsibility that all GSM7 models are in conformity with the applicable requirements of EN60601-1 following the provisions of the Low Voltage Directive 73/23/EEC.

All GSM7 models are certified to be in compliance with the applicable requirements of UL2601-1 (Patient Care Equipment), CSA 22.2 No. 234 (with additional tests to C22.2 No 601.1 per T.I.L. CA-08), EN 60601-1. Classification (in accordance with sub-clause 5 of EN60601-1):

- (5.1) Protection against electric shock = class II
- (5.2) Degree of protection against electric shock = signal output or intermediate
- (5.3) Protection against harmful ingress of water = ordinary (no protection)
- (5.5) Not suitable for use in the presence of flammable anesthetic mixture
- (5.6) Mode of operation = continuous

#### Earth Leakage Current

Leakage current measured in ground wire connection to output common.

#### Leakage Current

| Model | Normal | Single Fault | Test Voltage | Test Method |
|-------|--------|--------------|--------------|-------------|
| GSM7  | 32 µA  | 50 µA        | 132 Vac/60Hz | UL2601-1    |
| GMS7  | 55 µA  | 85 µA        | 264 Vac/50Hz | IEC601-1    |

\* Normal condition \*\*Single fault condition

# GSM7 Medical 7 Watt Single Output

| Model   | Output | Current | Load Regulation | Initial Setpoint Tolerance | OVP Setpoint | Ripple and Noise |
|---------|--------|---------|-----------------|----------------------------|--------------|------------------|
| GSM7-5  | 5.1 V  | 1.4 A   | 0.75%           | 2.5%                       | 6.2 ± 0.6 V  | 1%               |
| GSM7-12 | 12 V   | 0.6 A   | 0.75%           | 2.5%                       | 14 ± 1.1 V   | 1%               |
| GSM7-15 | 15 V   | 0.5 A   | 0.75%           | 2.5%                       | 18.5 ± 1.5 V | 1%               |
| GSM7-24 | 24 V   | 0.3 A   | 0.75%           | 2.5%                       | 28 ± 2.5 V   | 1%               |
| GSM7-28 | 28 V   | 0.3 A   | 0.75%           | 2.5%                       | 34 ± 2.8 V   | 1%               |

**NOT RECOMMENDED FOR NEW DESIGNS**  
**GSM7 SERIES TO BE DISCONTINUED IN 2006**  
**SEE GSM11 SERIES FOR DROP IN REPLACEMENT**

## GSM7 MECHANICAL SPECIFICATIONS

INPUT: J1

MOLEX P/N: 22-43-8030

W/CENTER PIN REMOVED: 0.098 CTR HEADER

PIN1 AC NEUTRAL  
 PIN3 AC LINE

MOLEXP/N: 22-43-8020  
 0.098 CTR HEADER

OUTPUT: J2

PIN1 +V  
 PIN2 RETURN

MATING CONNECTOR MOLEX P/N'S

|           | HOUSING    | CONTACT    |
|-----------|------------|------------|
| INPUT: J1 | 50-37-5033 | 08-70-1040 |
| OUTPUT:   | 50-37-5023 | 08-70-1040 |

NOTE: 2A MAX. RECOMMENDED CURRENT PER CONNECTOR PIN.

WEIGHT 2 OZ. MAX. (0.057kg)

TOLERANCES:

X.XX ± 0.030 (0.76MM)

X.XXX ± 0.010 (0.25MM)

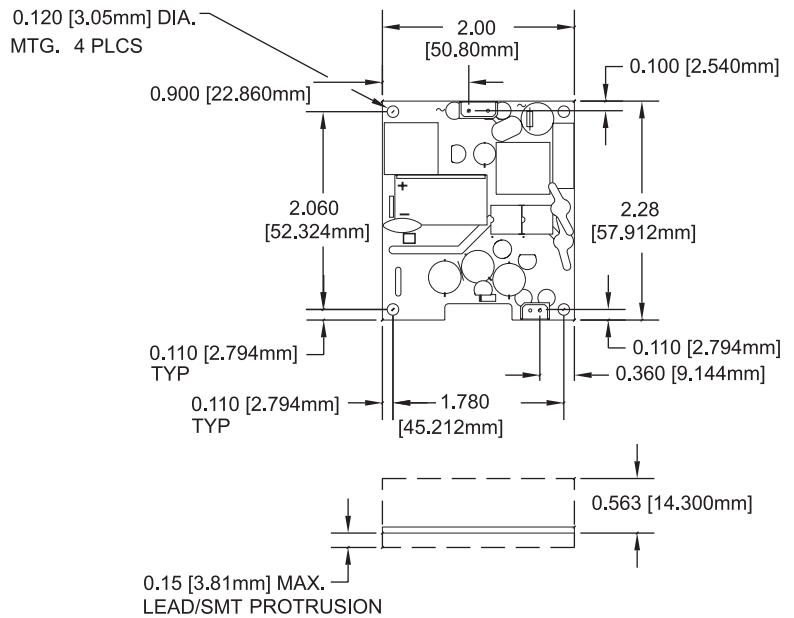

| Environmental Specification | Operating                                       | Non-operating                                 |
|-----------------------------|---|---|
| Temperature (A)             | 0 to 50°C                                       | -40 to +85°C                                  |
| Humidity (A)                | 0 to 95% RH                                     | 0 to 95% RH                                   |
| Shock (B)                   | 20 g <sub>pk</sub>                              | 40 g <sub>pk</sub>                            |
| Altitude                    | -500 to 10,000 ft                               | -500 to 40,000 ft                             |
| Vibration (C)               | 1.5 g <sub>rms</sub> , 0.003 g <sup>2</sup> /Hz | 5 g <sub>rms</sub> , 0.026 g <sup>2</sup> /Hz |

- A. Units should be allowed to warm up/operate under non-condensing conditions before application of power.
- B. Shock testing—half-sinusoidal, 10 ± 3 ms duration, ± direction, 3 orthogonal axes, total 6 shocks.
- C. Random vibration—10 to 2000Hz, 6dB/octave roll-off from 350 to 2000Hz, 3 orthogonal axes. Tested for 10 min./axis operating and 1 hr./axis non-operating.