

DC-DC converter AVP/J and AVP/K

Output power up to 75 Watts

Isolated – Single Output
PCB Mounting

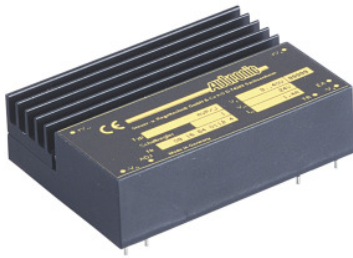

AVP/J



AVP/K

Block Diagram

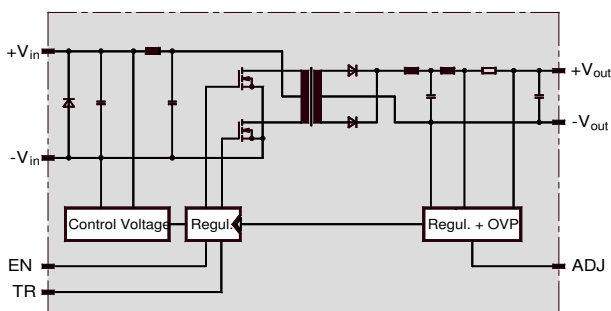

Technology

- MOSFET design
- Regulators in surface mount technology

Special Features

- Burst transients according to EN 61000-4-4:2004 (class 3): 2 kV
- Surge according to EN 61000-4-5:2006: 0,5 kV symmetric
- Conducted immunity according to EN 61000-4-6:1996
- Conducted emission: Input filtering according to EN 55022:2006, class A* (AVPK)
- Reverse polarity protection (by external fuse)
- Zero load operation and short circuit protected
- Parallel and series connection
- Overtemperature shutdown
- No overshoot of output voltage at switching on
- Remote off (EN) with TTL – L-signal
- Overvoltage protection in the output circuit, even in case of external supply (OVP)
- Extremely low thermal stress of sensitive components due to dissipated power loss over mounting surface
- Vibration resistant and indifferent to humidity due to encapsulated case

Specifications

at $\vartheta_{amb}=25^{\circ}\text{C}$, $V_{in\ nom}$, $0,62 I_{out\ nom}$

Temperature		
Ambient air	ϑ_{amb}	= $-40^{\circ}\text{C}...+85^{\circ}\text{C}$
Storage	ϑ_S	= $-40^{\circ}\text{C}...+100^{\circ}\text{C}$
Rise in case	$\Delta \vartheta_{C\ perm}$	$\leq 20\ \text{K}$
Permissible rise on heat sink	$\Delta \vartheta_B\ perm$	$\leq 25\ \text{K}$
Output voltages		
Tolerance (AVP/Ks)	ΔV_{out}	$\leq \pm 0,25\ (0,5)\%^{**}$
Output ripple at $\vartheta_{amb} = -40^{\circ}\text{C}...+85^{\circ}\text{C}$	$V_{out\ ripple}$	$\leq 3,5\%$
Temperature coefficient	TC	$\leq 0,016\%/K$
Regulation at $\vartheta_{amb} = -40^{\circ}\text{C}...+85^{\circ}\text{C}$		
Line reg. for $V_{in\ range}$	ΔV_{out}	$\leq 2\text{mV}$
Load reg. static	ΔV_{out}	$\leq 0,6\text{mV/A}$
Load change (25°C)*** for AVP/J	ΔV_{out}	$\leq 100\ (50)\text{mV/A}$
for AVP/K		$\leq 35\ (50)\text{mV/A}$
OVP		
Starting point /% admissible continuous external current AVP/J / K	$V_{out\ off}$	$\leq 130\% V_{out\ nom}$
	I_{ext}	$\leq 2,5/3,5\text{A}$
Isolation voltage-strength		
In-/Output		$\geq 1,5\text{kVrms}$
Input to base plate		$\geq 1,5\ \text{kVrms}$
Output to base plate		$\geq 0,3\ \text{kVrms}$
Resistance	$R_{iso/}$	$\geq 10^{11}\ \Omega$
Capacitance	$C_{iso/}$	$\geq 2200\ \text{nF}$
Weight AVP/J / AVP/K	M	ca. 260/330g

* In built-in condition our devices may show different EMC properties

** At 3,3 V and 5 V double values.

*** $I_{out\ min} = 0,1 I_{ou\ nom}$

Drawings

Dimensions in mm
Tolerance: general ±1mm

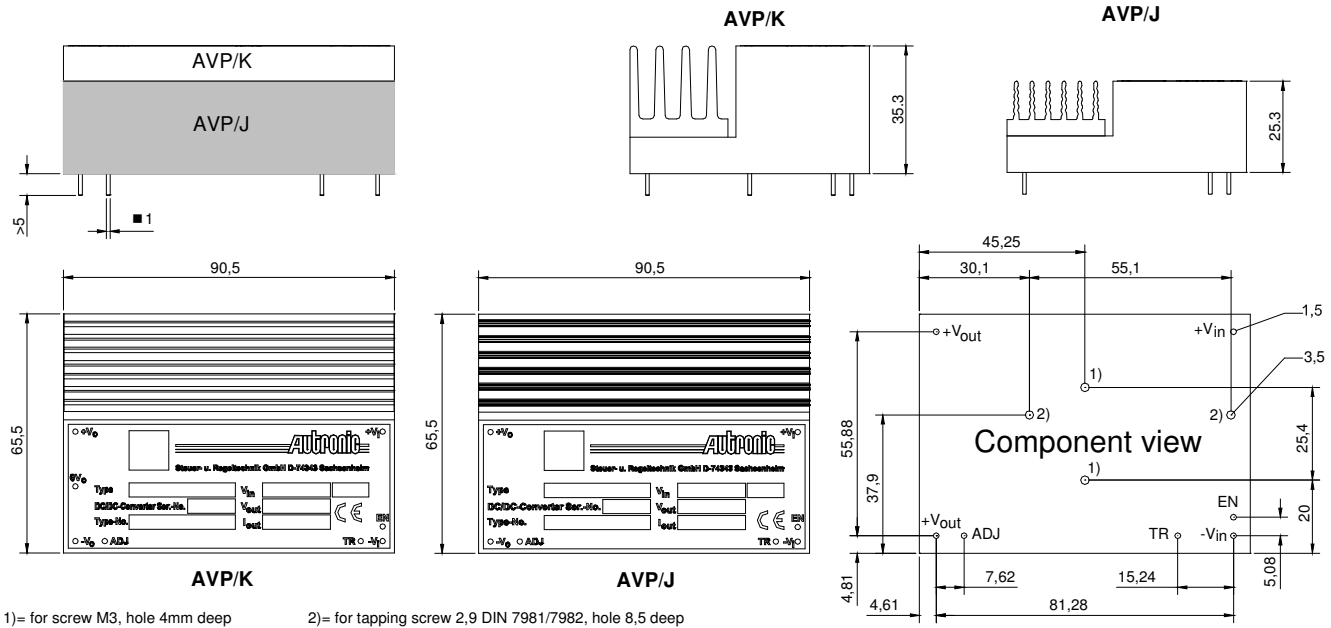

Operating instructions

Installation: The converters have to be installed according to the guidelines currently in force, like other open electronic component assemblies. Attention must be paid to sufficient ventilation, fastening and protection against accidental contact!

Reverse polarity protection: If reverse polarity connection of the input voltage can not be excluded, an external time-lag fuse must be installed. Size: $I_{rat} = 1,5 \times I_{in max}$ (max. 16 A). Pay attention on sufficient current of current in source in case of short-circuit.

Excess temperature protection: In case temperature exceeds 101 °C, typ. 105 °C, (due to inadmissible operation conditions) the output voltage is automatically switched off and restarted after cooling down about 10 K.

Overvoltage protection: Externally or internally caused overvoltage at the output leads to a thyristor-controlled short-circuit and shutdown of the output. After elimination of the overvoltage the output voltage restarts automatically.

External shut down (EN): $V < 0,8 V$ at pin "EN" to pin $-V_{in}$ switches off the output. $I_{source} 500\mu A$.

Current limiting: $I_{out lim} = 1,1 \dots 1,2 I_{out nom}$. At more than $1,5 I_{out nom}$, the output switches off and restarts automatically latest after 1s of elimination of the overload.

Tracking operation: If the TR pins of two or more converters are connected, the output voltages in case of short-circuit or overload go synchronously down.

Adjustment: Connection of the pin "ADJ" with the negative output pin increases the output voltage of about 8%. Intermediate values are obtained by means of a resistor. By connecting pin "ADJ" with the positive output pin over a resistor, the output may be lowered by max. 8%.

Standard converters AVP/J and AVP/K

V _{out} V	V _{in nom} V	V _{in range} V	AVP/J (25...42 Watts)				Order Number	AVP/K (38...75 Watts)				Order Number
			I _{out nom} ²⁾ A	I _{in max} A	η ³⁾ %	f kHz		I _{out nom} ²⁾ A	I _{in max} A	η ³⁾ %	f kHz	
3,3 ¹⁾	12/24	5...36 ⁴⁾	-	-	-	-	-	10	10	72	67	09 09 80 0112 6
5 ¹⁾	12/24	5...36 ⁴⁾	4,8	6,4	79	67	09 16 81 0112 3	7,2	10	80	67	09 09 81 0112 5
	12/24	9...40	5,6	4,0	82		09 16 61 0112 7	8,8	6,4	82		09 09 61 0112 9
	24	15...36	6,4	2,7	83		09 16 91 0112 1	9,6	4,0	84		09 09 91 0112 3
	48	32...74	6,4	1,3	82		09 16 51 0112 9	10	2,1	84		09 09 51 0112 2
	110	66...154	6,4	0,7	82		09 16 71 0112 5	10	1,1	85		09 09 71 0112 7
12	12/24	5...36 ⁴⁾	1,9	6,3	79	67	09 16 82 0112 2	2,9	9,5	80	67	09 09 82 0112 4
	12/24	9...40	2,7	4,5	83		09 16 62 0112 6	3,5	6,7	84		09 09 62 0112 8
	24	15...36	3,2	2,9	85		09 16 92 0112 9	4,8	4,5	86		09 09 92 0112 2
	48	32...74	3,2	1,5	86		09 16 52 0112 8	4,8	2,1	89		09 09 52 0112 1
	72	43...101	3,2	1,1	86		09 16 22 0112 5	4,8	1,6	89		09 09 22 0112 7
	110	66...154	3,2	0,8	85		09 16 72 0112 4	4,8	1,1	90		09 09 72 0112 6
15	12/24	5...36 ⁴⁾	1,5	5,9	79	67	09 16 83 0112 1	2,6	10	81	67	09 09 83 0112 3
	12/24	9...40	2,1	4,3	84		09 16 63 0112 5	3,4	6,9	85		09 09 63 0112 7
	24	15...36	2,6	3,1	86		09 16 93 0112 8	4,5	5,1	89		09 09 93 0112 1
	48	32...74	2,6	1,5	85		09 16 53 0112 7	4,5	2,4	88		09 09 53 0112 9
	110	66...154	2,6	0,8	85		09 16 73 0112 3	4,5	1,1	90		09 09 73 0112 5
24	12/24	5...36 ⁴⁾	1,0	6,3	80	67	09 16 84 0112 9	1,6	10	81	67	09 09 84 0112 2
	12/24	9...40	1,4	4,7	83		09 16 64 0112 4	2,3	7,4	85		09 09 64 0112 6
	24	15...36	1,6	3,0	87		09 16 94 0112 7	3,2	5,9	89		09 09 94 0112 9
	48	32...74	1,6	1,5	87		09 16 54 0112 6	3,2	2,7	90		09 09 54 0112 8
	72	43...101	1,6	1,1	87		09 16 24 0112 3	3,2	2,1	90		09 09 24 0112 5
	110	66...154	1,6	0,8	86		09 16 74 0112 2	3,2	1,3	90		09 09 74 0112 4
30	12/24	5...36 ⁴⁾	0,8	6,3	80	67	09 16 85 0112 8	1,6	13	81	67	09 09 85 0112 1
	12/24	9...40	1,1	4,7	84		09 16 65 0112 3	2,2	9,2	85		09 09 65 0112 5
	24	15...36	1,4	3,4	86		09 16 95 0112 6	2,5	5,8	90		09 09 95 0112 8
	48	32...74	1,4	1,6	87		09 16 55 0112 5	2,5	2,7	91		09 09 55 0112 7
	110	66...154	1,4	0,8	87		09 16 75 0112 1	2,5	1,3	91		09 09 75 0112 3

1) Adjusted to 3,4 resp. 5,1 V.

2) for $v_{amb} = -40^{\circ}\text{C} \dots 85^{\circ}\text{C}$ at flowing air. (> 0,6 m/s velocity, airflow parallel to the heatsink fins).

At still air and v_{amb} from 55°C to 85°C derating 1,25%/°C.

At v_{amb} between 85°C and 95°C linear decreasing to 0 A.

3) At $V_{in nom}$ and 0,6 I_{out nom}

4) Converter switches on at $V_{in} > 8 \text{ V}$

In case of operation at $V_{in} < 7 \text{ V}$ 10% basic load is required.

Autronic Steuer- und Regeltechnik GmbH
Siemensstr. 17
D-74343 Sachsenheim
Tel. +49 (0) 7147/24-240
Fax +49 (0) 7147/24-252
<http://www.autronic.de>
E-Mail: vertrieb@autronic.de

DIN EN ISO 9001:2000 certified