

DIN EN ISO 9001 certified

Autronic

Steuer- u. Regeltechnik GmbH & Co KG D-74343 Sachsenheim

DC-DC Converter AVP-3/KEP-S and ...-3/KEP-SB

Output Power up to 87 Watts

Isolated - Triple-Output
Standard euro-rack size 19"

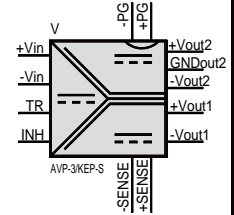

Special Features

- CE mark according EC directive 89/336/EWG and 73/23/EWG with improved specifications according to EN 50081-1:1992 and EN 61000-6-2:1999
- Electrostatic discharge: 8 kV contact (chassis) 15 kV air, EN 61000-4-2:1995 (level 4)
- Fast transients (Burst): 2 kV (criteria A)/ EN 61000-4-4:1995 (level 3)
- Surge: Input and output immunity (criterion A) according to EN 61000-4-5:1995: 2 kV symmetric, 2 kV asymmetric
- Conducted RFI:
 - Input filtering according to EN 55022:1998 class B
 - Output filtering according to Vfg 243/1991
- Zero load operation and short circuit protection
- Overtemperature shutdown
- Remote off (inhibit) with TTL - L-signal
- Overvoltage protection in the main output, even in case of external supply (OVP)
- Monitoring of the output voltage (fully isolated)
- Reverse polarity protection by int. fuse (diode at $V_{in} = 110V$)
- Fully integrated heatsink on back of converter chassis provides extremely low thermal stress to temperature sensitive components
- Yellow LED to indicate operating mode

Technology

- Power section in MOS-FET-technology
- Regulator section in SMT
- Coated assembly
- Coated and glued parts for better vibration resistance

Specifications

at $J_{amb} = 25^{\circ}C$, $V_{in nom}$, $I_{out nom}$

Temperature	
Ambient air	$J_{amb} = -40...+85^{\circ}C$
Storage	$J_S = -40...+100^{\circ}C$
Rise inside chassis	$DJ_{Ci} \leq 20 K$
Rise on heat sink	$DJ_H \leq 35 K$
Output voltages	
Tolerance $DV_{out1}/DV_{+out2}/DV_{-out2}/\%$	$\leq \pm 1/\pm 0,5/\pm 3$
Output ripple V_{out}/mV_{rms} at $J_{amb} = -40^{\circ}C...+85^{\circ}C$	$\leq 3,5$
Temperature coefficient $TC/\%/K$	$\leq 0,016$
Regulation at $J_{amb} = -40^{\circ}C...+85^{\circ}C$	
Line regulation DV_{out}/mV for 100% DV_{in}	≤ 2
Load reg. $DV_{out1 (+out2/-out2)}/mV$ per A load static	$\leq 10 (20/120^{**})$
$DV_{out1 (+out2/-out2)}/mV$ per A load change*	$\leq 38 (62/132^{**})$
Output "Power Good"	
Admissible voltage V_{CE0}/V	≤ 24
Admissible current I_C/mA	≤ 20
Saturation voltage $V_{CE(sat)}/V$	$\leq 1,2$
OVP	
Starting point $V_{out nom}/\%$	≤ 130
admissible continuous ext. current $I_{ext out1(+out2)}/A$	$\leq 6 (3)$
Isolation voltage-strength	
In-/Output V_{rms}/kV	$\geq 1,5$
Resistance R_{iso}/Ω	$\geq 10^{11}$
Capacitance $C_{iso out1 (out2)}/pF$	$= 8500 (6500)$
Chassis/input V_{rms}/kV	$\geq 1,5$
Chassis/output V_{rms}/kV	$\geq 0,5$
Output $V_{out1}/output V_{out2} V_{rms}/kV$	$\geq 0,3$
Capacitance $C_{iso out1/out2}/pF$	$= 12000$
Degrees of protection (inserted in rack)	$= IP20^{***}$
Weight M/g	$= 810$

Block Diagram

- 4 = $-V_{out1}$
- 6 = $+V_{out1}$
- 8 = $+Sense V_{out1}$
- 10 = $-Sense V_{out1}$
- 12 = $+V_{out2}$
- 14 = $GND V_{out2}$
- 16 = $-V_{out2}$
- 18 = $-PG$ (-Power Good)
- 20 = $+PG$ (+Power Good)
- 22 = TR (Tracking)
- 24 = INH (ON/OFF - inhibit)
- 26 = GND (TR und INH)
- 28 = $+V_{in}$
- 30 = $-V_{in}$
- 32 = Ψ/ϕ

Sense connection is not required

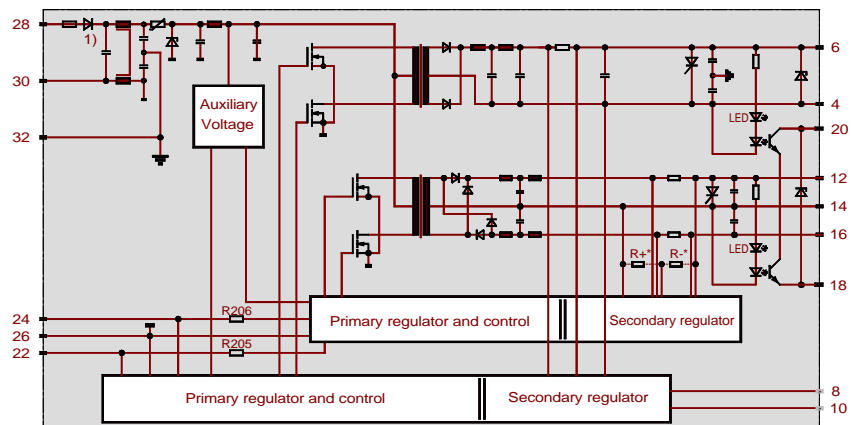

1) = only at $V_{in nom} = 110V$

* $I_{o min} = 0,1 I_{o nom}$

** The respective other output burdens with $I_{o nom}$.

*** Higher degrees of protection by properly mounting.

Maßbild AVP-3/KEP-S

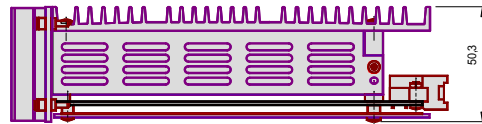

Dimensions in mm

Toleranz: general ± 1 mm
front panel DIN ISO 2768-1m

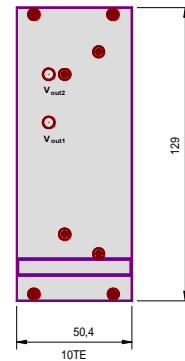
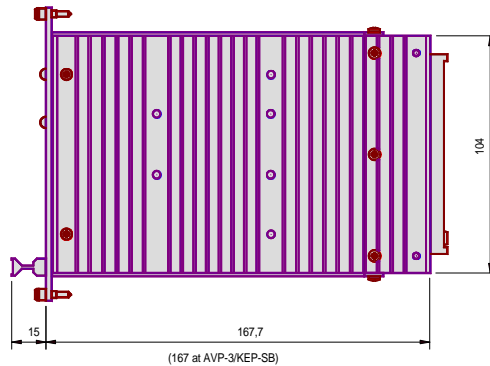
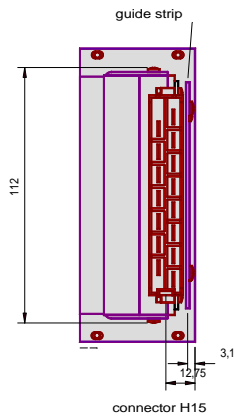

AVP-3/KEP-SB

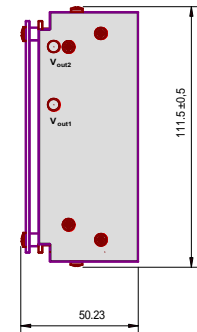

Mounting/Operating instructions

Installation: The converters have to be installed according to the guidelines currently in force, like other open electronic component assemblies. Attention must be paid to sufficient ventilation, fastening and protection against accidental contact! Plug in not under voltage if converter connected parallel or in series.

Reverse polarity protection: The converters are equipped with a soldered-in time-lag fuse corresponding to IEC 127-2 for input protection. For rating of fuse refer to listing below. Pay attention on sufficient current of current source in case of short-circuit ($t_r < 300$ ms)!

Connector pin 32 (∇ / \oplus) - Equipotentiality/PE: This pin has to be properly connected in order to assure operation.

Excess temperature protection: In case of inside temperatures exceeding 101°C , typ. 105°C , (due to inadmissible operation conditions) the output voltages are automatically switched off and restarted after cooling down about 10 K, after removing the 0-Ohm-Resistor at R205 only V_{out1} .

External shut down (inhibit): $V < 0,8$ V at pin 24 (inhibit) to pin 26 or connecting an active transistor with open collector to this pins switches off the outputs, after removing the 0-Ohm-Resistor at R205 only V_{out1} . $I_{source} 500 \mu\text{A}$.

Overvoltage protection: Internally caused overvoltages at the outputs lead to a thyristor-controlled short-circuit of the concerned positive output and all outputs shut down, also at external caused overvoltages at the positive outputs. After elimination of the overvoltages the outputs restart automatically. After removing the 0-Ohm-resistor at R205 the output voltages V_{out1} and V_{out2} shut down separately.

Current limiting: $I_{out\ lim} = 1,1 \dots 1,2 I_{out\ nom}$. At more than 50% overload, the output switches off and restarts automatically latest after 1s of elimination of the overload.

Tracking operation: If the pins 22 as well as 26 of two or more converters are connected, the output voltages in case of short-circuit or overload go synchronously down and restart at the same moment, after removing the 0-Ohm-Resistor at R205 only V_{out1} .

Power Good Output: Simultaneous with the lighting of two LEDs two transistors with open-collector without potential switches on (summary signal). Failure is indicated if one or both LEDs switches off. Level see table below.

Sense operation: Sense connection is not required. If it is accomplished, the voltage at the load is reduced by approx. 100 mV. The voltage drop on the interconnection leads between the converter and the load should not exceed 0,5 V.

Standard converters AVP-3/KEP-S and ...-3/KEP-SB

$\frac{V_{out1}}{V}$	$\frac{I_{out1}}{A}$	$\frac{\pm V_{out2}}{V}$	$\frac{\pm I_{out2}}{A}$	η^{***} %	$\frac{V_{PG}^{****}}{VDC}$	$\frac{V_{in\ nom}}{VDC}$	$\frac{V_{in\ op}}{VDC}$	$\frac{V_{in\ max}}{VDC}$	$\frac{I_{in\ max}}{A}$	$\frac{I_{rat}}{A}$	Order Number AVP-3/KEP-S	Order Number AVP-3/KEP-SB
5*	10	12	1,5	84	>3,5/>9,5	24	17...31	15...36	7,2	16	09 53 92 0102 7	09 53 92 0161 3
		15	1,2	84	>3,5/>13						09 53 93 0102 6	09 53 93 0161 2
		12	1,5	83	>3,5/>9,5	48	33...62	32...74	3,6	6,3	09 53 52 0102 6	09 53 52 0161 2
		15	1,2	83	>3,5/>13						09 53 53 0102 5	09 53 53 0161 1
		12	1,5	83	>3,5/>9,5	110	77...138	66...154	1,6	2,5	09 53 72 0102 2	09 53 72 0161 7
		15	1,2	83	>3,5/>13						09 53 73 0102 1	09 53 73 0161 6

Order numbers for option "EMC fingerstrips" and options on request

Specifications subject to change without notice

* Adjusted to 5,1 V

** At $-25^\circ\text{C} \dots +70^\circ\text{C}$. Derating between 70°C and 85°C : 4%/°C

*** At $V_{in\ nom}$ and $I_{out1\ nom, out2\ nom}$; typical

**** V_{PG} = Switching point for the output level for "Power Good"

Autronic Steuer- und Regeltechnik GmbH & Co. KG
Siemensstr. 17
D-74343 Sachsenheim
Telephone +49 7147 24-0
Telefax +49 7147 24-252
<http://www.autronic.de>